

---

# R-60 Audio Console

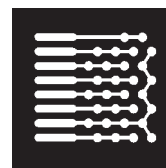

---

**R-60 Audio Console Technical Manual - 2nd Edition**

©1998 Audioarts® Engineering

(a division of Wheatstone Corporation)

AUDIOARTS ENGINEERING  
600 Industrial Drive  
New Bern, North Carolina 28562  
tel 252-638-7000 / fax 252-637-1285

---

# Attention!

## This console contains static sensitive devices:

Normal precautions against static discharge should be observed when handling individual modules.

## Replacing Modules in a Powered-up Console:

While in an emergency situation it is possible to remove and insert modules on a powered-up R-60 console, Wheatstone does not recommend this procedure. Whenever possible it is best to power down the console first before removing or replacing modules.

However, if you find you must proceed with this operation, then be sure to take the following precaution:



**When re-inserting a module, take care to replug it squarely into its mainframe connector socket, so all edgecard fingers make contact simultaneously.** In other words, the gold-plated bus connector fingers on the bottom edge of the module's printed circuit board must be inserted squarely (i.e., perpendicular) to the mating socket on the bottom pan of the console mainframe. **The intent is to prevent a situation where one of the module's power pins makes significant contact before the others.** (Naturally, this same precaution must be taken when using extender ribbon cables.)

The easiest way to assure correct contact is to press on the top (toward the meterbridge) surface of the module while seating it. The angle that the connector fingers make to the panel will automatically assure the correct alignment if the top surface of the panel is pressured first. *Do NOT press on the lower surface of the panel until the top part of the connector is seated.*

If the above instructions are followed the procedure should be routine; if they are not, you could run the risk of damaging the console's logic chips (located on the control room and studio modules).

Again, to avoid ANY possibility of this damage, whenever possible we strongly recommend powering down the R-60 console *before* replacing any modules.

## ATTENTION

### Module Plugging Order:



Certain modules in the R60 console *must be located at specific positions* in the frame. If they are not, module failure could result and the affected modules *would NOT be covered under warranty*.

Simply put, the OM-60 output module, CR-60 control room module and SC-60 studio module *must be located in the last three RH positions* of the R-60 mainframe in the order shown in the drawing. All remaining slots may be populated with IN-60 input modules, TR-60 tape remote module(s), or the SP-60 Simple Phone module.

NOTE the R-60 mainframe can accommodate only ONE SP-60 Simple Phone module per console.

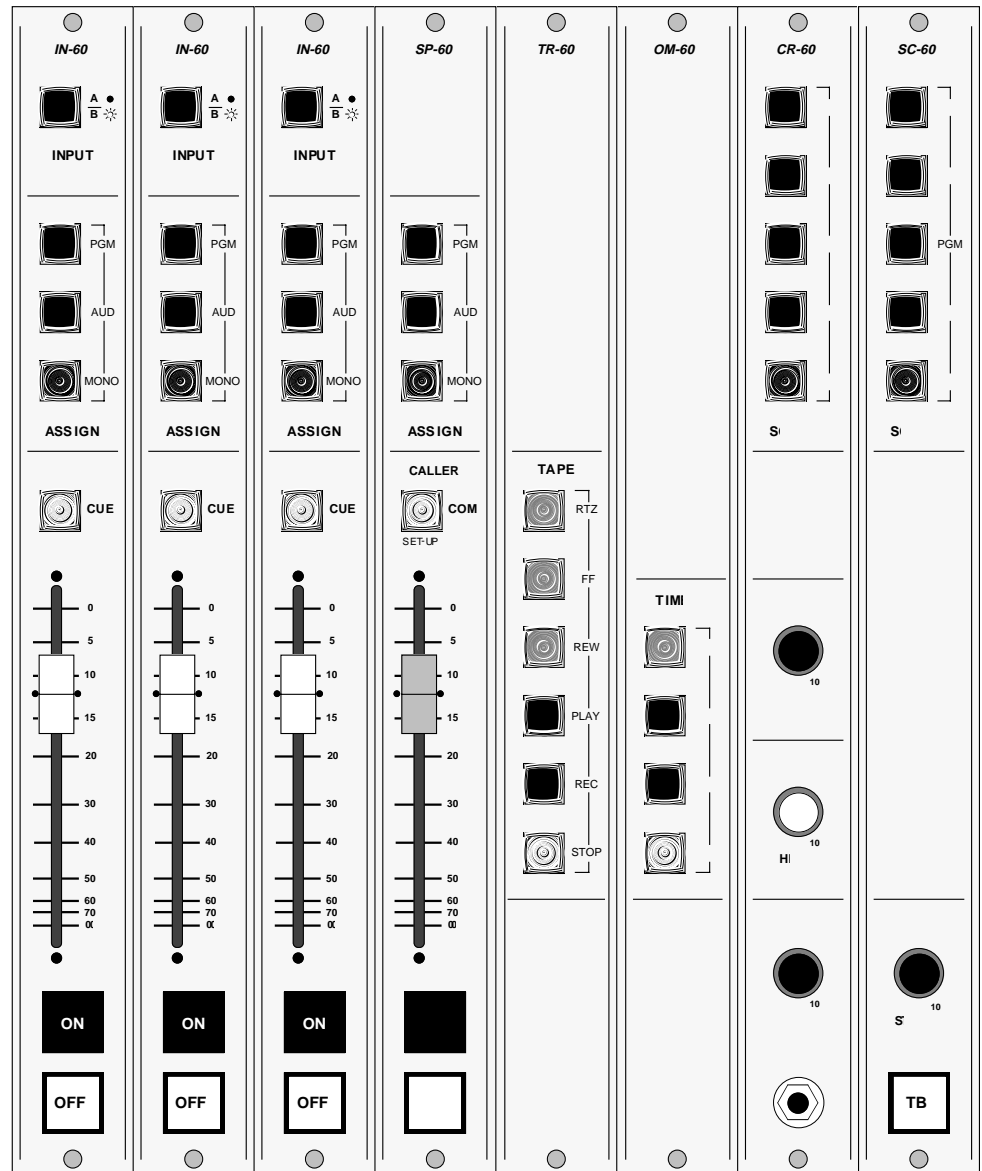

NOTE the last three slots in the R-60 mainframe are dedicated to specific modules!

etc. ←

Extreme RH slot  
**DEDICATED**  
Must be  
SC-60  
Studio  
Module

If you have any questions concerning this, please contact our factory customer support department.

---

# Attention!

## Console Clock Battery Backup

To activate battery backup of the console's clock simply pull out the yellow strip from the clock display card, that is mounted on the inside of console meterbridge, as shown on the picture below.

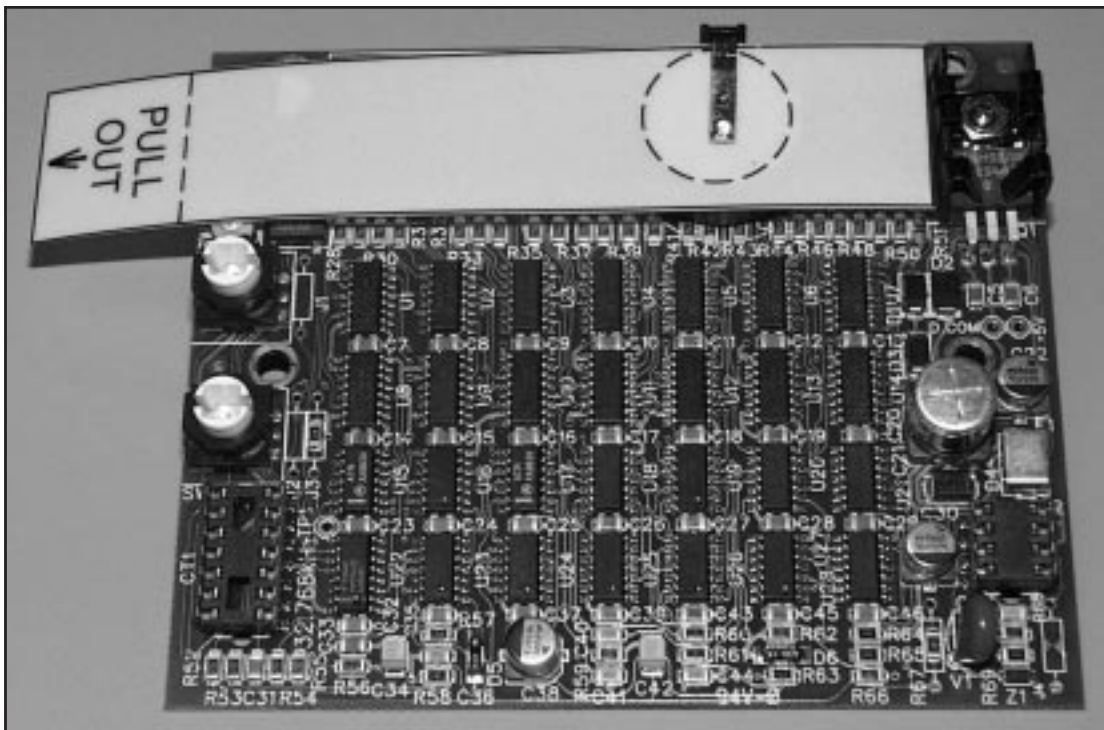

Console Clock Display Card

## HAND CRIMP TOOL WIRING INSTRUCTIONS

The supplied hand crimping tool (PALADIN model PA1645, W/S#850067) is used for all I/O wiring connections to and from the console. It is to be used with the supplied .062" pin diameter silver crimp terminals (figure 1) intended for 22 gauge wire.

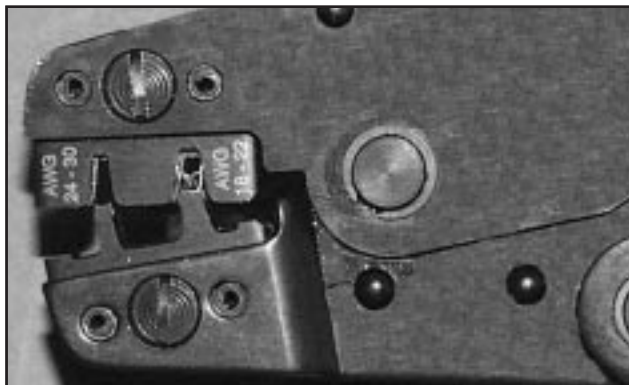

(2) The terminal conductor tabs (pointing UP) are placed in anvil 18-22; the terminal's insulation tabs extend in front towards the camera.

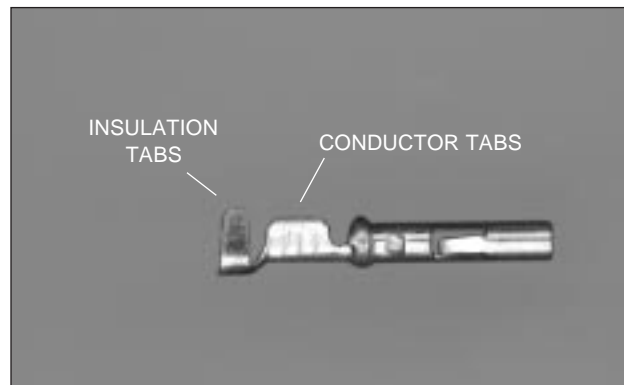

(1) .062" pin diameter silver crimp terminal

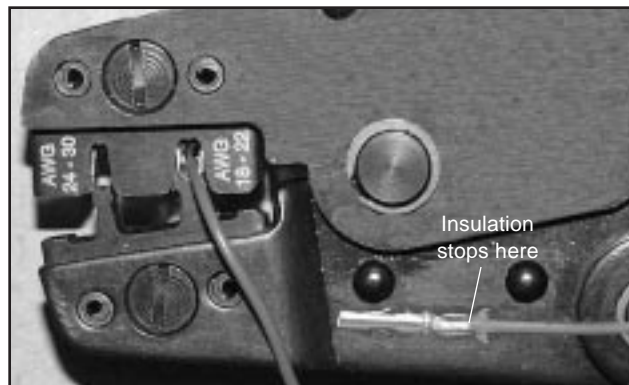

(3) The stripped 22 gauge wire is placed into the terminal and crimped. Note the wire's insulation must stop just short of the conductor tabs (detail)

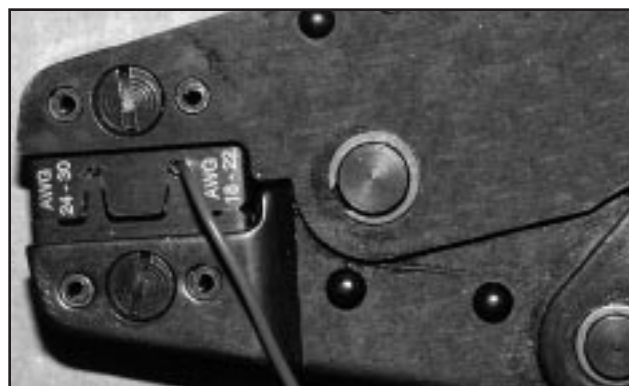

(4) Final step: jaws fully closed; the insulation tabs have been crimped.

1) Strip wire approximately 3/16" (insert in proper wire stripper, rotate one half turn, and pull insulation off wire).

2) Leaving wire aside for the moment, with Paladin tool fully open (engraved side toward you) bring a terminal into position from the unmarked side of the tool. Place the conductor tabs (inner set as shown in figure 1) on the "18-22" or "24-30" (depending on the wire) anvil (slightly curved surface) so that the circular portion of the tabs rests in the curved surface of the anvil and the two tabs face up into the walls of the female jaw. The insulation tabs will be flush with the top of the tool (figure 2).

3) Close tool very slightly, only to the point of holding the terminal in position (figure 2).

4) Insert wire into terminal until wire insulation is stopped by conductor tabs (figure 3). CRIMP by squeezing handles until jaws are fully closed.

5) If there is an insertion error or if a circuit change is needed, you'll need to use an extractor tool to remove terminals (next section).

## EXTRACTOR PIN INSTRUCTIONS

If you should accidentally insert a crimp terminal pin into the wrong socket, the supplied pin extractor tool (Waldom P/N W-HT-2023) will let you correct your mistake without having to sacrifice a connector.

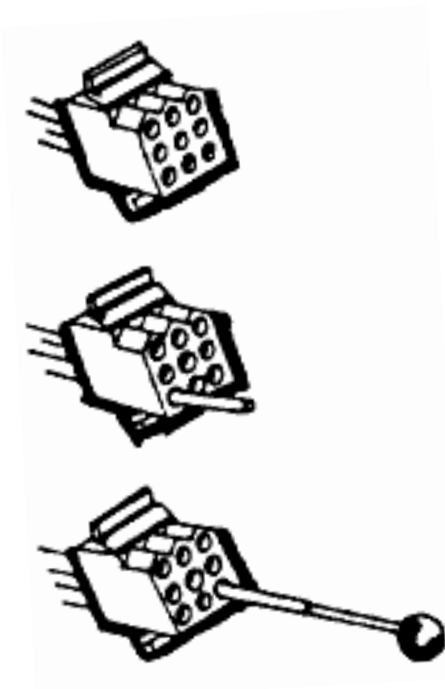

**STEP 1.**  
Push wire attached to pin terminal, to be removed, forward to free pin terminal locking flanges from the Nylon Connector Housing.

**STEP 2.**  
Place extractor tip over pin terminal to be removed. Press handle portion of extractor in downward motion until tip rests upon Nylon Housing.

**STEP 3.**  
Push ball at top of extractor down toward pin terminal; pin terminal will extract from Nylon Housing.

---

# Table of Contents

## Console Overview

SYSTEM DESCRIPTION .....	1-1
STANDARD MODULES .....	1-1
OPTIONAL MODULES .....	1-2
PERFORMANCE SPECIFICATIONS .....	1-2
MODULE FACEPLATE DRAWING .....	1-4
SYSTEM SIGNAL FLOW DIAGRAM .....	1-5

## Mainframe Installation

UNPACKING THE CONSOLE .....	2-1
PREPARING FOR INSTALLATION .....	2-1
INSTALLATION OF OPTIONS .....	2-2
Installing an Optional DMP-60 Mic Preamp .....	2-2
Installing the LS-60 Line Selector .....	2-2
SYSTEM GROUND .....	2-3
Typical Grounding Scheme (dwg) .....	2-4

## Console Logic & I/O Connections

GENERAL .....	3-1
CONSOLE LOGIC .....	3-3
MODULE CONTROL PORTS .....	3-7
TYPICAL IN-60 REMOTE LOGIC (sch dwg) .....	3-8
ON-AIR TALLY CIRCUIT .....	3-8a
MODULE I/O CONNECTIONS .....	3-9
COMPLETING THE INSTALLATION .....	3-17
POWER SUPPLY INSTALLATION and CONNECTION .....	3-17
VU METER ALIGNMENT .....	3-17
CLOSING UP THE CONSOLE .....	3-17

## Console Operation

FADER AND LEVEL CONTROLS .....	4-1
INPUT AND OUTPUT ASSIGN SWITCHES .....	4-1
CUEING .....	4-2
THE CONSOLE CLOCK .....	4-2

## Module Controls

IN-60 INPUT MODULE .....	5-2
CR-60 CONTROL ROOM MODULE .....	5-3
SC-60 STUDIO MODULE .....	5-4
OM-60 OUTPUT MODULE .....	5-5
SP-60 SIMPLEPHONE .....	5-6
TR-60 TAPE REMOTE MODULE .....	5-7
LS-60 LINE PRESELECTOR .....	5-7



**Schematic Drawings**

IN-60 INPUT .....	6-2
DMP-60 DUAL MIC PREAMP .....	6-5
SP-60 SIMPLE PHONE .....	6-6
TR-60 TAPE REMOTE .....	6-9
OM-60 OUTPUT .....	6-10
CR-60 CONTROL ROOM .....	6-11
SC-60 STUDIO CONTROL .....	6-14
TM-6 TIMER .....	6-17
CLK-5 CLOCK .....	6-18
PS-6040 POWER SUPPLY .....	6-19
LF-60 LOGIC FOLLOW .....	6-20
LS-60 LINE SELECT .....	6-21

**Load Sheets**

R-60 EXT MOTHER BOARD .....	7-2
R-60 MOTHER BOARD .....	7-3
IN-60 INPUT MODULE .....	7-4
INS-60 SWITCH BOARD .....	7-5
DMP-60 DUAL MIC PREAMP .....	7-6
OM-60 BOARD .....	7-7
TCS-60 TIMER CONTROL SWITCH CARD .....	7-8
CR-60 CONTROL ROOM MODULE .....	7-9
SC-60 STUDIO CONTROL MODULE .....	7-10
MS-60 MONITOR SWITCH CARD .....	7-11
SP-60 SIMPLE PHONE INPUT .....	7-12
TR-60 BOARD .....	7-13
TM-6 TIMER CARD .....	7-14
CLK-5 CLOCK .....	7-15
PS-6040 POWER SUPPLY .....	7-16
LF-60 LOGIC FOLLOW .....	7-17
LS-60 LINE SELECT .....	7-18

**Parts Lists**

Completed Modules .....	8-2
IN-60 Input Module .....	8-3
DMP-60 Dual Mic Preamp PCB .....	8-6
SP-60 Simple Phone® Module .....	8-7
TR-60 Tape Remote .....	8-10
OM-60 Output Module .....	8-11
CR-60 Control Room Module .....	8-13
SC-60 Studio Control Module .....	8-16
TM-6 timer .....	8-19
CLK-5 clock .....	8-21
PS-6040 Power Supply .....	8-23
Power Supply Cable .....	8-26
LF-60 Logic Follow PCB .....	8-27
LS-60 Line Selector Panel .....	8-28
Frame-60 – 18 Position Mainframe .....	8-29
EXT-60 Extender Ribbon .....	8-32
Completed sub-assemblies .....	8-33
Spare Parts Kit (optional) .....	8-34

**Troubleshooting**

BASIC PROCEDURES .....	9-1
EXT-60 RIBBON EXTENDER ASSEMBLY .....	9-2
INTEGRATED CIRCUITS .....	9-2

---

# Console Overview

## Chapter Contents:

System Description .....	1-1
Standard Modules .....	1-1
Optional Modules .....	1-2
Performance Specifications .....	1-2
Module Faceplate Drawing .....	1-4
System Signal Flow Diagram .....	1-5

## SYSTEM DESCRIPTION

For a better understanding of the console, refer to the R-60 console module faceplate drawing (page 1-4) and system signal flow diagram (page 1-5) in conjunction with the following section.

The WHEATSTONE AUDIOARTS R-60 AUDIO CONSOLE is designed for radio on-air applications. The console comes supplied with two stereo (PROGRAM and AUDITION) and one MONO output. The mainframe comes supplied with 12 or 18 input modules (IN-60), a dual mono microphone preamplifier (DMP-60) assignable to any two input modules, a control room module (CR-60), a studio control module (SC-60), 1 expansion and 1 accessory position. All module switching is LED illuminated. The console meterbridge houses 4 VU meters (PGM LT, PGM RT, AUD LT and AUD RT), a 6 switch preselector bank, digital timer, and an internal CUE speaker. The 18 input version also contains a clock and can accommodate a second (optional) preselector bank. A rackmount power supply is included.

### Standard Modules

(1) IN-60 INPUT module: a dual source stereo line input module with A/B select switch, output assign switches (PGM, AUD, MONO), CUE switch, a long-throw conductive plastic fader, lighted channel ON and OFF switches, and internal gain trimmers for left and right. Logic functions, selectable via internal dipswitch, are as follows: talkback to studio; control room mute; studio mute; cue dropout; local/external control of ready (OFF) lamp; cue enable; and timer restart. The module also has the following external control ports: remote on, remote off, on tally, ready, remote start, remote stop, cough, and talkback. Thus the module combines the logic functions of both line and microphone inputs.

(2) DMP-60 MIC PREAMP module (mounted in console meterbridge): a dual mono microphone preamplifier with transformer input. The module outputs are normally wired to the A inputs of two IN-60 modules. The module contains separate gain trimmers for each preamp.

(3) OM-60 OUTPUT module: a stereo output module with two independent channels (PROGRAM and AUDITION) which are electronically balanced to assure noise-free performance and compatibility with external equipment. Easily accessible internally mounted trimpots are provided for calibration and stereo balancing. The module is also provided with insert points in both PGM and AUD for external signal processing, such as EQ or compression. Timer control is provided by four switches (AUTO, START/STOP, RESET and HOLD). The timer's automatic restart function causes it to reset to zero and begin counting up upon activation of any pre-programmed input channel.

(4) CR-60 CONTROL ROOM module: selects control room monitor source (EXT 1 & 2, PGM, AUD, and MONO), control room level, headphone level, and cue level. When activated, CUE interrupts the headphone signal; it can also be programmed (via internal dipswitch) to interrupt left and/or right control room signals. An on-air tally relay is also included. The module's headphone circuit has a built-in internal amplifier as well as an external port.

(5) SC-60 STUDIO CONTROL module: selects monitor source (EXT 1 & 2, PGM, AUD, and MONO). The module also contains a TB switch (to implement the talkback to studio function), and a studio level control. Note the console's mono output circuitry is located on the studio module.

## Optional Modules

(1) LS-60 LINE PRESELECTOR SWITCHBANK (mounted in console meterbridge): a 6-position switchbank allowing selection of one of six balanced stereo inputs; its output can be wired to any of the IN-10 inputs, or to the EXT inputs of the CR-10 or the SC-10 modules.

(2) TR-60 TAPE REMOTE MODULE: allows full remote control of one tape or cart machine (FF-1 version) or Start/Stop control of three machines (SS-3 version). The switches have LED illumination which is powered by the external source machines.

(3) SP-60 SIMPLE PHONE module: Used for automated phone segments; automatically creates a mix-minus from any one of its three bus select buttons, receives all signals from the selected bus, feeds them to the caller, and then automatically routes those signals and the caller back to the bus without any feedback or feedback null circuitry. The SP-60 module does not connect directly to the telephone line. It must be connected to a telephone hybrid.

## Performance Specifications

(Unless otherwise noted, test conditions are +4dBu output; +4dBu line input, -50dBu mic input)

### FREQUENCY RESPONSE

Line (10Hz-20KHz)  $\pm 1/10$ dB

Mic (20Hz-20KHz)  $\pm 1/10$ dB

### DYNAMIC RANGE

Line 114dB

Mic 98dB

### OFF ISOLATION

1KHz -110dB

20KHz -105dB

### ASSIGN ISOLATION

1KHz -110dB

20KHz -105dB

---

**S/N RATIO** (ref +8dBu)

Line 94dB  
Mic 78dB

**HEADROOM**

ref +4dBu 24dB

**THD + N** (20Hz-20KHz)

Line, +4dBu .005%  
Line, +16dBu .005%  
Mic, +16dBu .005%

**IMD** (SMPTE)

Line, +4dBu .004%  
Mic, +4dBu .004%

**DIM**

Line, +16dBu .005%  
Mic, +16dBu .005%

**CMMR**

(@60Hz) -65dB

**MAXIMUM INPUT**

Line +28dBu  
Mic -10dBu

**MAXIMUM OUTPUT**

+28dBu

**MAXIMUM INPUT GAIN**

Line 26dB  
Mic 90dB

**BUS CROSSTALK**

1KHz -100dB  
20KHz -75dB

**GAIN TRIM RANGE**

Line (-6dB to +14dB) 20dB  
Mic (-18dB to +20dB) 38dB

**SLEW RATE**

15V/ $\mu$ s

**PHASE RESPONSE**

input to output <20°

**PHASE DIFFERENCE**

left to right <1°

Specifications subject to change without notice.

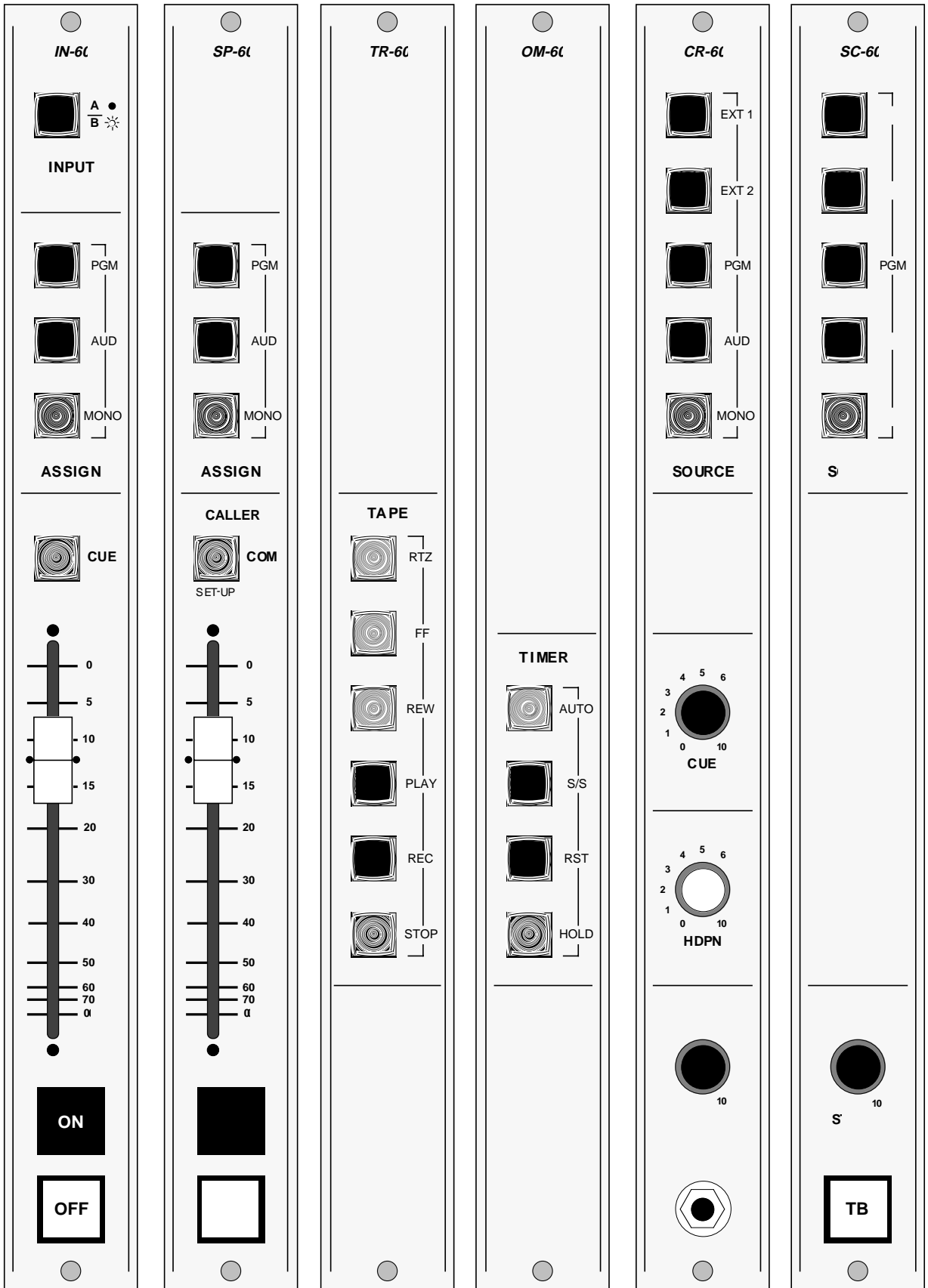

(Optional)

### R-60 Module Faceplates

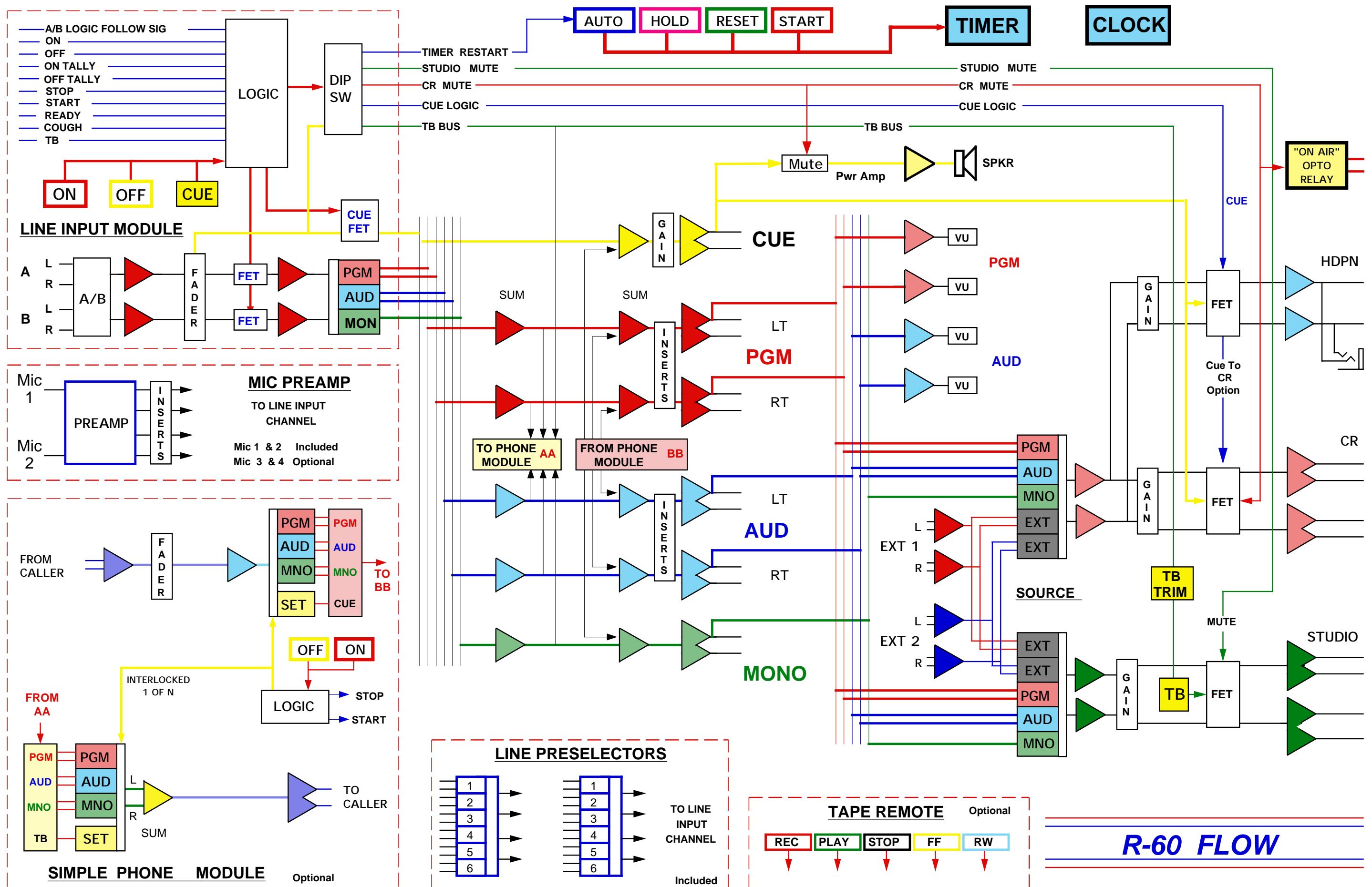

**R-60 FLOW**

# Mainframe Installation

## Chapter Contents

Unpacking the Console .....	2-1
Preparing for Installation .....	2-1
Installation of Options .....	2-2
Installing the DMP-60 Mic Preamp .....	2-2
Installing the LS-60 Line Preselector .....	2-2
System Ground .....	2-3
Typical Grounding Scheme (dwg) .....	2-4

**To install the AUDIOARTS R-60 Console, perform the following steps carefully:**

## UNPACKING THE CONSOLE

The console is normally shipped as two or more packages. One carton contains the console and documentation, while additional cartons contain the Power Supply and connecting cable, plus any options (i.e., mic preamps or line preselectors).

## PREPARING FOR INSTALLATION

**DO NOT CONNECT THE R-60 CONSOLE TO ITS POWER SUPPLY, AND DO NOT CONNECT THE POWER SUPPLY TO THE AC POWER LINE, UNTIL INSTRUCTED TO DO SO.**

It is not necessary to prepare the counter by making a cutout, since the R-60 is mounted above the counter top. If you will be securing the console to the counter top, you may want to pre-drill the mounting holes (see sketch below).

Set the console in place on the counter and remove the screws that hold the modules in place (two per module), and also the three screws that hold down the hinged meterbridge. This is necessary to provide access to the console's I/O connections.

Carefully remove all modules from the frame.

Attach the console mainframe to the counter top, using the holes provided in the bottom of the chassis and screws appropriate to the counter material.

NOTE: This console contains static-sensitive devices. Normal precautions against static discharge should be observed when handling individual modules.

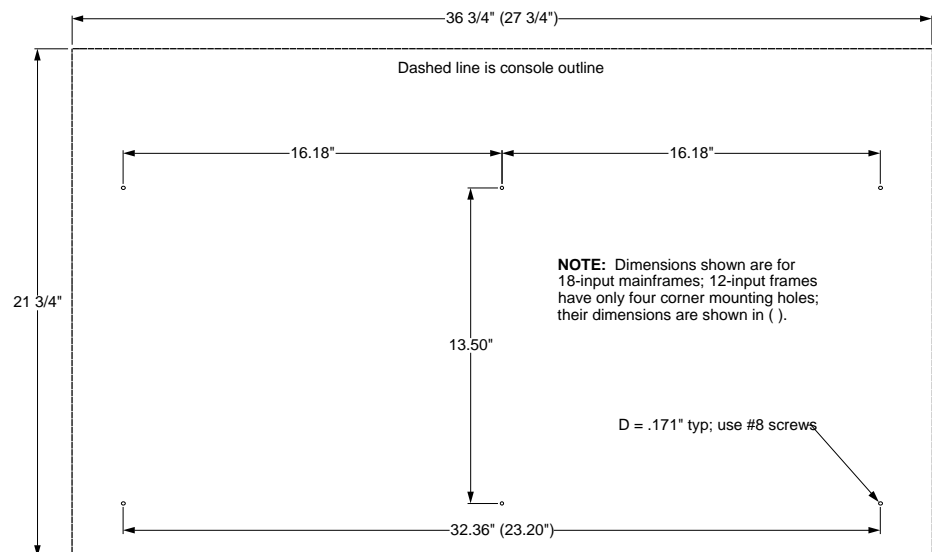



## INSTALLATION OF OPTIONS

**The following two options are available for user installation:** second (or third) DMP-60 Dual Microphone Preamplifier plus (18 input frame only) one additional LS-60 Line Preselector.

### Installing Optional DMP-60 Mic Preamp(s)

The DMP-60 option comes complete with mounting hardware and ribbon cable for providing power to the card. Handle the 8 pin plugs on the ribbon cable assembly with care; the pins are sharp and fragile. Perform the following steps to install the DMP-60:

- (1) turn off the power to the console;
- (2) remove the last five righthand modules from the console mainframe;
- (3) remove the three screws that hold down the meterbridge, and open the meterbridge;
- (4) attach the DMP-60 preamp assembly directly to the right of the factory installed preamp (located at the lefthand end of the meterbridge), using four type 4-40 screws and four nylon standoffs through the four pre-drilled holes below the meterbridge hinge screws. Orient it to match the factory installation;
- (5) connect one end of the supplied ribbon cable assembly to the 8 pin DIP socket on the DMP-60 board ("CT3"), making sure that pin 1 of the plug matches pin 1 of the socket;
- (6) thread the ribbon cable down the meterbridge to the RH end, and pass it through the opening in the rear of the console mainframe;
- (10) connect the other end of the ribbon assembly to an unused 8 pin Mic Preamp Power DIP socket (CT57, CT58 or CT61), located at the front edge of the right end of the R-60 mother board, making sure that pin 1 of the plug matches pin 1 of the socket;
- (11) connect the required audio wiring to the 12 pin connectors on the DMP-60 card, referring to the connector pinout chart (see Chapter 3);
- (12) proceed with the installation of any other options, or close and secure the meterbridge and reinstall the removed modules if no other options are to be installed.

This completes the DMP-60 installation procedure.

### Installing a Second LS-60 Line Preselector

These steps apply to 18-input mainframes ONLY. The LS-60 Line Preselector assembly is shipped attached to its mounting bracket. The bracket attaches to the console mainframe with 4 type 6-32 screws, included in the kit. Perform the following steps to install the LS-60:

- (1) turn off the power to the console;
- (2) remove modules from mainframe positions 18, 19 and 20;

- (3) remove the three screws that hold down the meterbridge, and open the meterbridge;
- (4) using a flat-bladed screwdriver, carefully pry off the line selector cutout cover (located under the console clock);
- (5) using the factory preselector as a guide, line the LS-60 up in position so the four mounting holes in the bracket line up with the pre-drilled mounting holes in the console frame;
- (6) install the mounting screws, but don't tighten them;
- (7) close the meterbridge slowly, checking to see that the meterbridge clears the LS-60;
- (8) if necessary, open the meterbridge and adjust the LS-60 position for best clearance and centering of the switches within the line selector cutout;
- (9) when the correct position has been achieved, tighten the screws securely;
- (10) make the signal connections to the 12 pin connectors on the LS-60, referring to the connector pinout chart (see Chapter 3);
- (11) reinstall the modules removed in step 2;
- (12) proceed with the installation of any other options, or close and secure the meterbridge if no other options are to be installed.

This completes the LS-60 installation procedure.

**Once option installation is complete, check that each item is correctly installed before continuing.**

## SYSTEM GROUND

Note that the console power supply common, audio common, and the mainframe chassis are connected together at the mainframe, but are not connected to electrical ground and the chassis of the power supply as supplied by the factory. Safety requirements dictate that a positive connection from the mainframe to electrical ground be made in the completed installation; use one of the grounding lugs on the bottom of the mainframe (centered on the outside rear chassis panel, just above countertop level) to establish your system ground.

The system ground serves two important purposes:

- (1) Provides a zero signal reference point for the entire audio system;
- (2) Assures safety from electrical shock.

There exist two terms that one encounters in a discussion of ground:

- (A) EARTH GROUND, which is usually a heavy copper rod driven into the soil adjacent to the building (around 6 feet down) or a connection to the copper water pipes leading into the building. Either is acceptable, unless, of course, the water pipe is of the newer plastic variety.

**MAINFRAME INSTALLATION**

(B) THE POWER COMPANY EARTH CONDUCTOR that enters the building at the power line breaker box; this conductor should be (and is often by code) tied to the above-mentioned earth ground at one point. This point is the SYSTEM EARTH GROUND.

TIE THE CONSOLE GROUND LUG TERMINAL STRIP TO THE SYSTEM EARTH GROUND. TIE EVERY PIECE OF EQUIPMENT IN THE ENTIRE AUDIO SYSTEM TO THE CONSOLE GROUND LUG TERMINAL STRIP. If the system earth ground point is inaccessible, tie the console ground terminal strip to the power company earth conductor at the main breaker box (see drawing "Typical Grounding Scheme" below).

Tie the console ground lug terminal strip to the system earth ground. Tie every piece of equipment in the entire audio system to the console ground lug terminal strip.

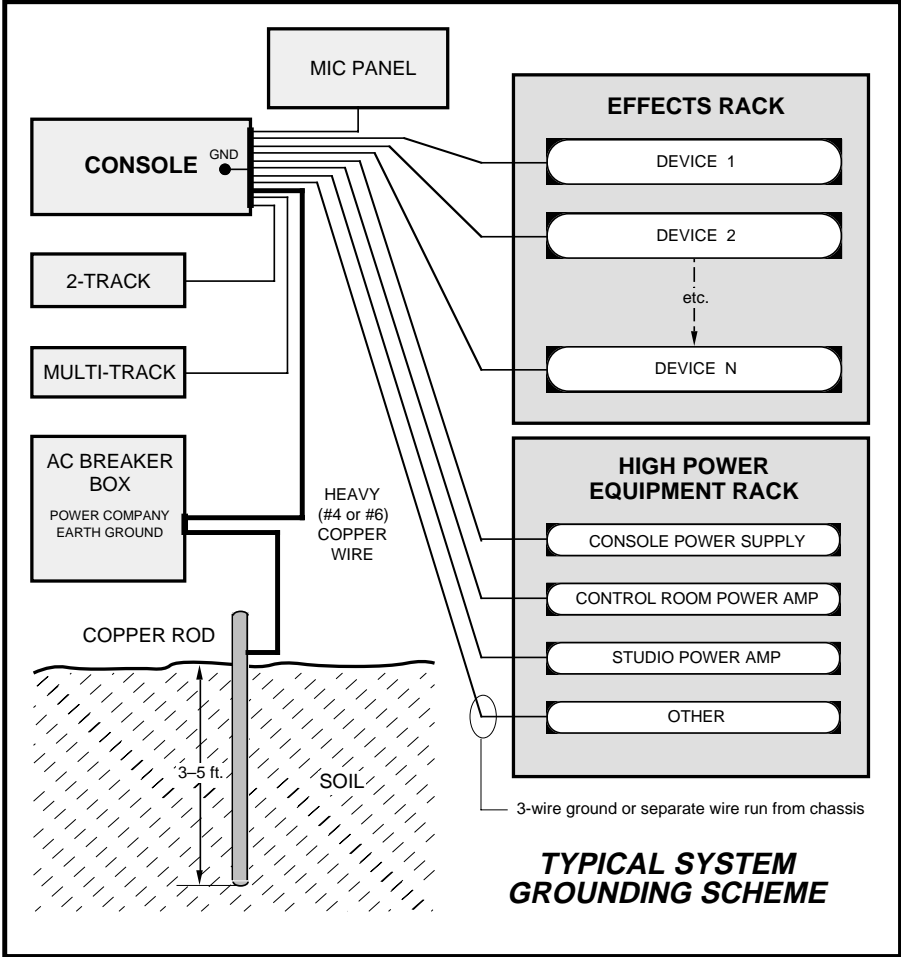

Each piece of equipment should be connected by its own ground wire (usually the round third pin on the AC cord). This means that every AC outlet must have a separate conductor run to the console ground lug terminal strip; the outlets cannot be daisy-chained as is normally encountered in commercial and residential AC systems. Any equipment not supplied with 3-wire AC cables must have individual ground wires (16 gauge or larger) connected to their chassis grounds and then run to the console ground lug terminal strip.

### **Further Details**

Check all equipment to be absolutely certain that each unit is power transformer isolated from the AC mains to prevent safety hazards.

It is assumed that in each piece of audio equipment the audio ground and the chassis are tied together at some point. Any piece of equipment lacking a grounded chassis is likely to be prone to interference problems.

Locate all unbalanced audio equipment in the same rack if possible, to minimize chassis ground potential differences. It may also be helpful to insulate each piece of unbalanced equipment from its mounting rails in the rack by means of nylon 10-32 screws and insulating washers between rails and faceplates.

**Once the system is properly grounded, you may proceed with the audio and control input/output connections (next chapter).**

---

# Console Logic & I/O Connections

## Chapter Contents

General .....	3-1
Console Logic .....	3-3
Module Control Ports .....	3-7
Typical IN-60 Remote Logic (schematic dwg) .....	3-8
On-Air Tally Circuit .....	3-8a
Module I/O Connections .....	3-9
Completing the Installation .....	3-17
Power Supply Installation and Connection .....	3-17
VU Meter Alignment .....	3-17
Closing up the Console .....	3-17

## GENERAL

See LOAD SHEETS chapter, specifically drawings for R-60 motherboards on pages 7-2 and 7-3, for locations of I/O connectors

All audio and control I/O connections to the R-60 console are made through 12-pin connectors with locking tabs that connect to mating connectors on the console mother boards, mic preamps, line preselector, and tape remote modules. There is one audio connector and one logic connector per input channel, and there are 7 connectors in the output/CR/SC section of the mother board for insert and output connections and on-air relay connections. In the meterbridge, there are two connectors on the DMP-60 dual mic preamp module (and 2 more for each additional optional DMP-60), 4 connectors on the optional line preselector, 2 connectors on the optional tape remote and 2 connectors for the optional logic follow card.

As supplied from the factory, the console requires no logic connections to function. Therefore an orderly installation begins with the audio wiring. Once proper audio operation is verified (i.e., no ground loops), proceed with the control wiring.

The supplied 12 pin connectors use crimp type pins. A crimp tool must be used, and an extraction tool is handy to remove pins that have been inserted in the wrong connector block hole, or if rewiring or wiring repair is needed in the future. Always be careful to double check pin numbering on the connector block and the wiring diagram before inserting the pin in the block.

Consoles are normally supplied with the outputs of the mic preamp wired to the "A" inputs of IN-60 modules 1 and 2. Channel 1 is preprogrammed to mute the control room speakers, so you won't hear anything from the control room speakers if channel 1 is turned ON. Channel 2 is preprogrammed to mute the studio speakers, so you won't hear anything from those speakers if channel 2 is turned ON. These mutes can be reprogrammed; see the section on dipswitch controlled functions.

The I/O connections can now be made. Note that a gap is provided at the back of the console, at the bottom, for cable entry.

Refer to the Module I/O Pinout text to connect the console to your equipment. Note that each IN-60 module is a dual stereo input ("A" and "B") line level module. If a microphone level input is desired, route the signal to one of the DMP-60 inputs. The DMP-60 outputs are normally connected to the "A" inputs of the first IN-60 modules. Recommended setup is to have all

microphones connected to the first channels, with the remaining channels used as line inputs. Group input types together. For example, if you have three cart machines, connect them to the "A" inputs of three successive IN-60 modules.

Connect seldom used sources to the "B" inputs, if necessary. Another use of the "B" inputs is to duplicate the connections to often used sources, giving a level of signal security through redundancy. Note that the "B" inputs should not be used for microphones in the studio or control room, since the studio and control room mute functions are not available at these inputs.

Refer to the Module I/O Connection Section and note that the audio signal connections follow a logical pattern. Pins are grouped in 4 groups (called pairs for this discussion) of 3 pins each (1-3, 4-6, 7-9, and 10-12). The first pin of each group (1, 4, 7, and 10) is audio common, or ground, for connection of shields. The next pin (2, 5, 8, and 11) is the low side for balanced signals, or ground for unbalanced signals. The third pin (3, 6, 9, and 12) is the high side for balanced signals, or the signal connection for unbalanced ones.

In the case of stereo signals, left is always assigned to the first (pins 1-3) or third (pins 7-9) pair of a connector, and right is always assigned to the second (pins 4-6) or fourth (pins 10-12) pair.

The console is provided with insert connectors on both the PGM and the AUD signals. The insert points (unbalanced) are normally dipswitch bypassed, so if you do not plan on doing any processing of these signals you can leave the insert connectors unconnected. If you wish to insert some type of processing device in either of these lines, you must wire to the insert connector in question. Note that the insert output is wired to the external device's input, and the external device's output wires back to the console insert input. Note also that DIP SW1 that normally bypasses the insert point must be turned off if the inserts are to be used. Turn off the correct position of the dip switch according to the chart below:

LT PGM	Pos 1
RT PGM	Pos 2
LT AUD	Pos 3
RT AUD	Pos 4

Although insert points are not included for each channel separately, the mic channels may be processed by considering the connection from the DMP-60 output to the IN-60 input as an insert point. Wire the DMP-60 output to the external device's input, and wire the external device's output to the IN-60 input.

Once the signal wiring is complete, check that each item is correctly wired before continuing.

Key diagram showing back of typical 12-pin I/O connector plug, with pin numbers oriented as they would be seen while wiring. Beveled corners correspond to PCB mounted mating sockets.

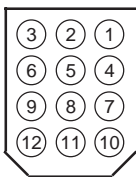

The Insert bypass dipswitch ("SW1") is located on the OM-60 output module printed circuit board.

## CONSOLE LOGIC

### Dipswitch Controlled Functions

See individual module load sheets (Chapter 7) for dipswitch locations

The dipswitch positions on each **input module** ("SW1" on the module's printed circuit board) are numbered from one to seven, and control the functions described below.

Note dipswitches are ON with the switch lever to the right, or OFF with the lever to the left.



(1) CUE DROPOUT - causes a channel that is in CUE to drop out of CUE when its ON button is pushed.



**NOTE:** If Cue Logic is turned on, headphone output WILL switch to CUE if any channel so programmed is in Cue mode. CR may also be affected.



(2) CUE LOGIC - interrupts the headphone signal with the CUE signal when the programmed channel is in CUE. CR can also be programmed for interruption; see the discussion on page 3-5 ("CR-60 control room 4-position dipswitch "SW1") for further information.



(3) CR MUTE - causes the console's control room output to be muted when a programmed module, with its A input selected, is triggered ON. This prevents control room feedback when the announcer's mic channel is open. Note that the internal cue speaker will mute when the CR output mutes.



(4) ST MUTE - causes the console's studio output to be muted when a programmed module, with its A input selected, is triggered ON. This function is used to prevent feedback when the studio announcer mic channel is open.

## CONSOLE LOGIC & I/O CONNECTIONS

Note dipswitches are ON with the switch lever to the right, or OFF with the lever to the left.



(5) **TIMER RESTART** - causes the console timer to automatically reset to zero and start counting when the programmed channel's ON button is pushed. (Note timer must already be counting in order to continue count after resetting to zero.)



(6) **LOCAL OFF ENABLE** - allows the channel's logic circuitry to control the illumination of the channel OFF lamp (as shown). If an external device, such as a cart machine, will control the channel OFF lamp, this dipswitch should be moved to its OFF position.



**NOTE:** The TB TO STUDIO function can only be programmed for ONE channel. Do NOT program dipswitch position 7 on multiple inputs.



(7) **TB TO STUDIO** - sends the module's pre-fader left signal to the studio talkback bus. This function is normally used on the announcer mic channel module to permit control room to studio communication. It is also activated to permit off-air caller set-ups in conjunction with the optional SP-60 Simplephone module (see p. 5-6).

**Typically, the IN-60 dipswitches as set up as described below:** this is the factory default setting. Input (IN-60) dipswitches are ON with the switch lever to the right, or OFF with the lever to the left.



Channel 1 is set up for a control room microphone. Position 7 of the dipswitch is ON to enable the Talkback-to-Studio function for that channel, allowing the console operator to talk to the studio by using the "TB" switch on the SC-60 module. **NOTE THAT ONLY ONE IN-60 MODULE CAN BE PROGRAMMED FOR TALKBACK TO STUDIO; PROGRAMMING OF THIS FUNCTION FOR MORE THAN ONE MODULE AT A TIME WILL RESULT IN SEVERE DISTORTION.** Position 3 of the switch is ON to enable the control room mute function for that channel, to prevent the control room mic signal from appearing at the control room speakers. Since the control room mic can talk to the studio via talkback, the studio mute function for that channel is disabled by turning position 4 of the switch OFF. Positions 1 and 2 are OFF since the cue function is not required for this signal. Position 6 is ON to enable local control of the OFF lamp. Position 5 is normally OFF. If it is turned ON, the console timer will be reset whenever the control room mic is turned ON.



## CONSOLE LOGIC & I/O CONNECTIONS

Note dipswitches are ON with the switch lever to the right, or OFF with the lever to the left.



Channel 2 is set up for a studio microphone. Position 7 of the dipswitch is OFF to disable the Talkback-to-Studio function for that channel. Position 3 of the switch is OFF to disable control room mute. Position 4 of the switch is ON to enable the studio mute function, which prevents feedback through the studio monitors when the channel is open. Positions 1 and 2 are OFF since the cue function is not required for this signal. Position 6 is ON to enable local control of the OFF lamp. Position 5 is normally OFF. If it is turned ON, the console timer will be reset whenever the studio mic is turned ON.

If additional studio mics are used (requiring additional DMP-60 modules), they may be set up the same as the channel 2 module.

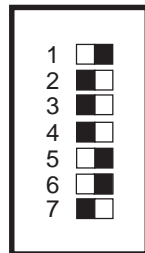

The remaining channels are line inputs, used with cart, CD, tape machines, or any other line level signal. Positions 7, 3 and 4 of the dipswitch are OFF, disabling Talkback-to-studio and the mutes. Position 2 is OFF, disabling the console's CUE LOGIC circuitry. This means CUE will NOT interrupt the console's control room and headphone outputs (though it will still appear at the console's meterbridge cue speaker). If you turn position 2 ON, remember: if any channel so programmed is in CUE, the headphones will switch to cue. This may lead an operator to believe that the headphone output is not working. By turning on position 1, CUE DROPOUT, the CUE switch can be left activated, and when the channel is turned ON by hitting the module's ON button, CUE will automatically be turned off. Position 5 is ON if the timer should start at zero when the channel is selected. Position 6 should be OFF if the machine connected to the module is set up to signal that it is READY by flashing the module OFF lamp; otherwise the switch is ON (the factory default setting) to enable the OFF lamp to be controlled by the module's logic.

**The CR-60 Control Room module contains a 4 position dipswitch ("SW1" on the printed circuit board) to provide the following 2 functions:**

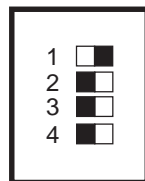

(1) CUE TO CR LEFT - interrupts the left control room speaker with the CUE signal whenever an IN-60 module programmed for CUE LOGIC is placed in CUE.

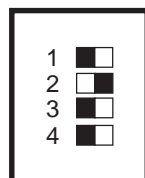

(2) CUE TO CR RIGHT - interrupts the right control room speaker with the CUE signal whenever an IN-60 module programmed for CUE LOGIC is placed in CUE.

**The SC-60 Studio module contains a 4 position dipswitch ("SW1" on the printed circuit board) that provides the following 2 functions:**

Note dipswitches are ON with the switch lever to the right, or OFF with the lever to the left.



(1) LEFT STUDIO DIM - attenuates the left studio output by approximately 20 dB whenever an IN-60 programmed for ST MUTE is on.

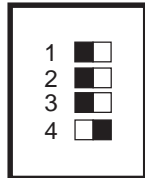

(4) RIGHT STUDIO DIM - attenuates the right studio output by approximately 20 dB whenever an IN-60 programmed for ST MUTE is on.

Note that these dipswitch functions may be used in any combination, according to the needs of the installation.

**Typically, the control room and studio module dipswitches are set up for CUE to interrupt control room left and right outputs, with the DIM function defeated on the studio module.**

**The OM-60 output module also contains a 4 position dipswitch ("SW1" on the printed circuit board) that bypasses Program and Audition insert points (the bypass is normally activated at the factory):**

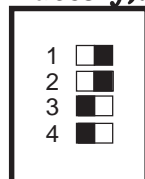

(1 & 2) PROGRAM LT & RT BYPASSES

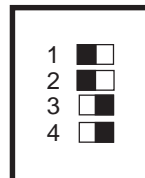

(3 & 4) AUDITION LT & RT BYPASSES

**The Simple Phone module contains a 4-position dipswitch ("SW1" on the printed circuit board) to provide the following 3 functions:**

Note dipswitches are ON with the switch lever to the right, or OFF with the lever to the left.



(1) CUE LOGIC - interrupts the headphone signal with the CUE signal when the module is in CUE. CR can also be programmed for interruption; see the discussion on page 3-5 ("CR-60 control room 4-position dipswitch "SW1") for further information.

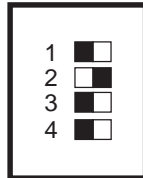

(2) CR MUTE - causes the console's control room output to be muted when the module is triggered ON. Note that the internal cue speaker will mute when the CR output mutes.



(4) TIMER RESTART - causes the console timer to automatically reset to zero and start counting when the module's ON button is pushed. (Note timer must already be counting in order to continue count after resetting to zero.)

Once the dipswitch settings have been made, check that each switch is correctly programmed before continuing.

## MODULE CONTROL PORTS

Key diagram showing back of typical 12-pin I/O connector plug, with pin numbers oriented as they would be seen while wiring. Beveled corners correspond to PCB mounted mating sockets.

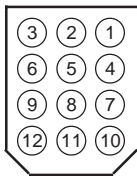

The following logic functions, listed by pin number, are available at the logic port of each IN-60 module:

- (1) REMOTE ON - connected momentarily to DIGITAL COMMON to turn channel on from a remote location.
- (2) REMOTE OFF - connected momentarily to DIGITAL COMMON to turn channel off from a remote location.
- (3) ON TALLY - permits a 5V lamp to be controlled by the module's channel ON circuit.
- (4) MACHINE COMMON - is provided so that remote machine START and STOP can function without the need to tie the console common and the remote machine common together.
- (5) REMOTE STOP - allows a remote machine to be stopped by pushing the module's channel OFF button.
- (6) REMOTE START - allows a remote machine to be started by pushing the module's channel ON button.
- (7) READY - allows a remote machine to control the module's channel OFF switch indicator lamp. The LOCAL OFF ENABLE dipswitch must be in the OFF position.)
- (8) COUGH - provides a remote momentary OFF function.
- (9) TALKBACK - a continuous contact closure from this line to digital common places the module in CUE. If the module's CUE ENABLE dipswitch is activated, the CUE bus signal is sent to the headphones, and to the control room speakers if so programmed at the CR/SC dipswitch.
- (10) LOGIC FOLLOW - provides a logic high of 5V when the module's A inputs are selected. The signal is used to light an LED indicator or otherwise used to develop A/B follow logic functions.
- (11) +5 VOLTS - provides power source for external circuitry.
- (12) DIGITAL COMMON - provides power return for external circuitry.

For controlling "on-air" tally functions, a relay closure is provided. This closure is available at 12 pin connector "CT34" in the control room section of the mainframe motherboard.

Refer to the Module I/O pinout text and wire the IN-60 logic connectors. Typically, a mic channel will use the REMOTE ON, REMOTE OFF, ON TALLY, COUGH, and TALKBACK signals, along with +5 VOLTS and DIGITAL COMMON. A line input will use REMOTE ON, REMOTE OFF, ON TALLY, REMOTE START, REMOTE STOP, and READY, along with +5 VOLTS, DIGITAL COMMON, and MACHINE COMMON. The schematic diagram ("Typical IN-60 Remote Logic"; next page) shows typical connections for both mic and line inputs.

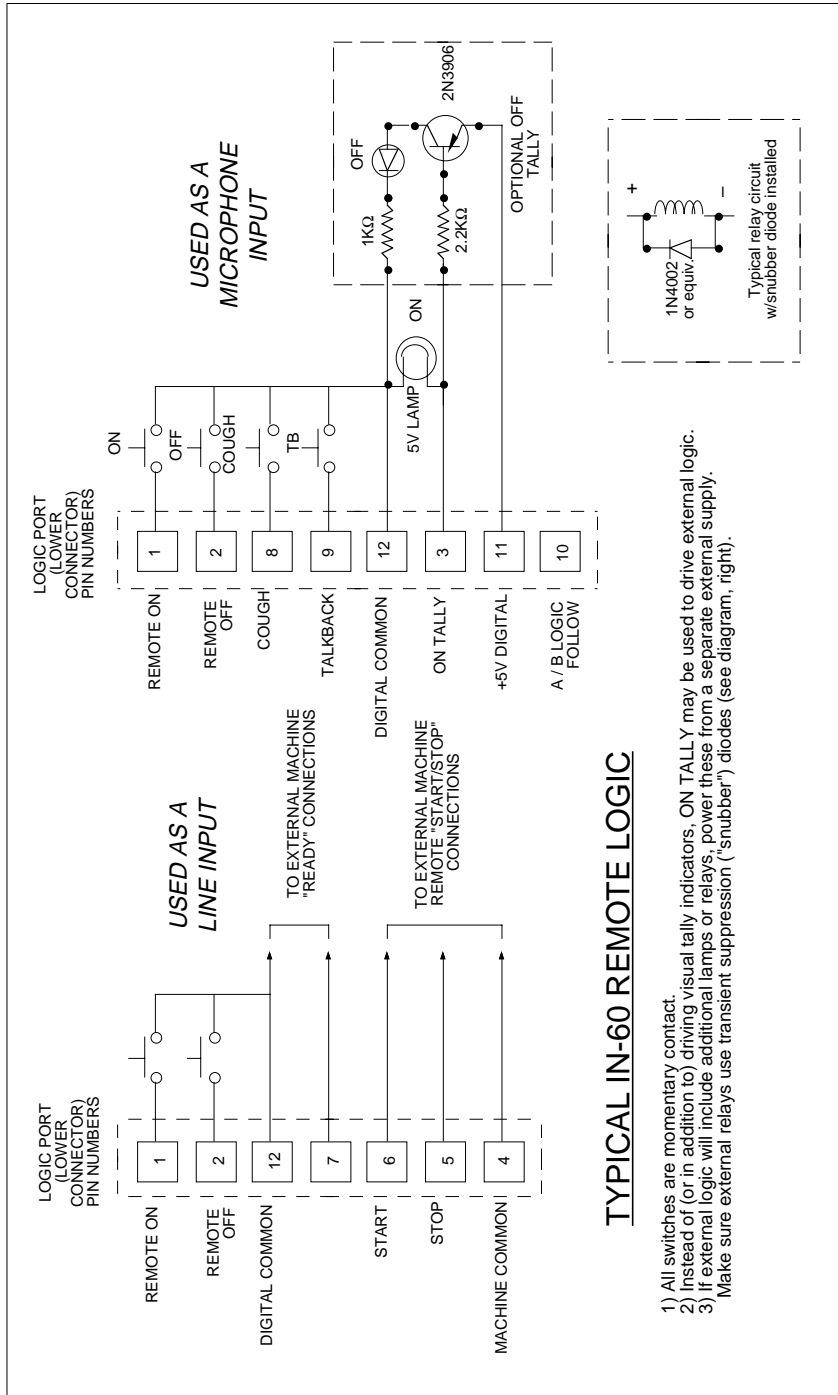

## On-Air Tally Circuit

For controlling “on-air” tally functions, an internal relay is provided. The tally may be activated by any IN-60 input module ON switch programmed to mute CR. The relay connections are available at a 12 pin connector (CT34) located just below the CR-60 monitor module's regular I/O connector.

Make your connections to the ON AIR light and its power source through the contacts of the EXTERNAL relay. **DO NOT UNDER ANY CIRCUMSTANCES RUN AC LINE VOLTAGE INTO THE CONSOLE.**

### TYPICAL CONTROL ROOM ON-AIR TALLY CIRCUIT

*USER-SUPPLIED RELAY TRIGGERED BY CONSOLE CR MUTE CIRCUIT*

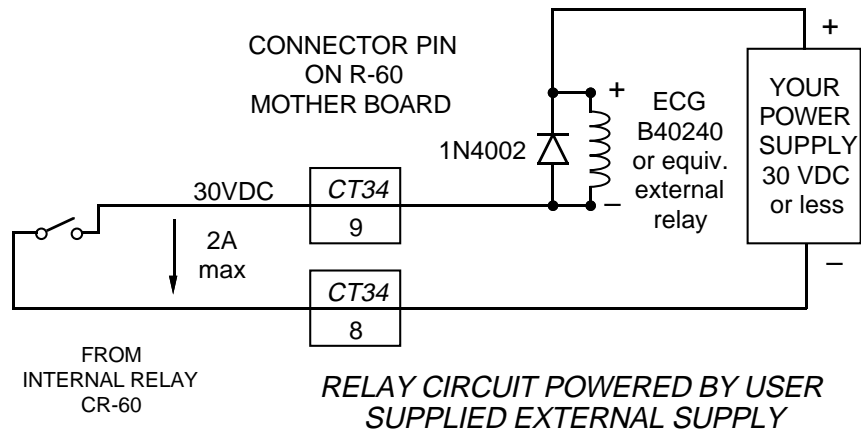

## MODULE I/O CONNECTIONS

Key diagram showing back of typical 12-pin I/O connector plug, with pin numbers oriented as they would be seen while wiring. Beveled corners correspond to PCB mounted mating sockets.

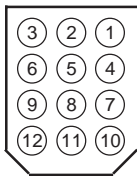

Module input/output signal connections are made via 12-pin AMP type connectors. Refer to the R-60 Mother board load sheet on page 7-2 for the exact location of specific connectors. Key drawing to left shows a typical connector. Note this key drawing applies to all 12-pin I/O connector text pinouts that follow in this section.

Note also that the audio signal connections follow a logical pattern. Pins are grouped in 4 groups (called pairs for this discussion) of 3 pins each (1-3, 4-6, 7-9, and 10-12). The first pin of each group (1, 4, 7, and 10) is audio common, or ground, for connection of shields. The next pin (2, 5, 8, and 11) is the low side for balanced signals, or ground for unbalanced signals. The third pin (3, 6, 9, and 12) is the high side for balanced signals, or the signal connection for unbalanced ones.

In the case of stereo signals, left is always assigned to the first (pins 1-3) or third (pins 7-9) pair of a connector, and right is always assigned to the second (pins 4-6) or fourth (pins 10-12) pair.

The PROGRAM, AUDITION, MONO, CONTROL ROOM and STUDIO outputs are electronically balanced, 10 ohms output impedance; minimum load is 600 ohms. **As the outputs are electronically balanced, care must be exercised when connecting them to an unbalanced system.** While temporarily shorting the low side of the output signal to ground will not cause any problems, continued operation will result in increased distortion, decreased reliability, and possible oscillation problems. **If you must connect the output to an unbalanced system, be sure to leave the low side unterminated, and connect the unbalanced system to the high side output and shield connections.**

### IN-60 Audio Input

(CT1-CT14, R-60 Mother Board load sheet dwg)

(CT1-CT6, R-60 Ext Mother Board load sheet dwg)

- Pin 1 - A INPUT LEFT, SHIELD
- Pin 2 - A INPUT LEFT, LOW
- Pin 3 - A INPUT LEFT, HIGH
- Pin 4 - A INPUT RIGHT, SHIELD
- Pin 5 - A INPUT RIGHT, LOW
- Pin 6 - A INPUT RIGHT, HIGH
- Pin 7 - B INPUT LEFT, SHIELD
- Pin 8 - B INPUT LEFT, LOW
- Pin 9 - B INPUT LEFT, HIGH
- Pin 10 - B INPUT RIGHT, SHIELD
- Pin 11 - B INPUT RIGHT, LOW
- Pin 12 - B INPUT RIGHT, HIGH

Key diagram showing back of typical 12-pin I/O connector plug, with pin numbers oriented as they would be seen while wiring. Beveled corners correspond to PCB mounted mating sockets.

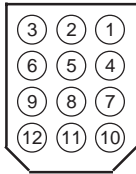

### IN-60 Logic

(CT19-CT32, R-60 Mother Board load sheet dwg)

(CT7-CT12, R-60 Ext Mother Board load sheet dwg)

- Pin 1 - REMOTE ON
- Pin 2 - REMOTE OFF
- Pin 3 - ON TALLY
- Pin 4 - MACHINE COMMON
- Pin 5 - REMOTE STOP
- Pin 6 - REMOTE START
- Pin 7 - READY
- Pin 8 - COUGH
- Pin 9 - TALKBACK
- Pin 10 - A/B LOGIC FOLLOW
- Pin 11 - +5V LOGIC SUPPLY (FUSED)
- Pin 12 - DIGITAL COMMON

### Program Inserts

(CT33, R-60 Mother Board load sheet dwg)

- Pin 1 - LEFT PROGRAM INSERT, FEED, SHIELD
- Pin 2 - AUDIO COMMON
- Pin 3 - LEFT PROGRAM INSERT, FEED, HIGH
- Pin 4 - RIGHT PROGRAM INSERT, FEED, SHIELD
- Pin 5 - AUDIO COMMON
- Pin 6 - RIGHT PROGRAM INSERT, FEED, HIGH
- Pin 7 - LEFT PROGRAM INSERT, RETURN, SHIELD
- Pin 8 - AUDIO COMMON
- Pin 9 - LEFT PROGRAM INSERT, RETURN, HIGH
- Pin 10 - RIGHT PROGRAM INSERT, RETURN, SHIELD
- Pin 11 - AUDIO COMMON
- Pin 12 - RIGHT PROGRAM INSERT, RETURN, HIGH

### Audition Inserts

(CT36, R-60 Mother Board load sheet dwg)

- Pin 1 - LEFT AUDITION INSERT, FEED, SHIELD
- Pin 2 - AUDIO COMMON
- Pin 3 - LEFT AUDITION INSERT, FEED, HIGH
- Pin 4 - RIGHT AUDITION INSERT, FEED, SHIELD
- Pin 5 - AUDIO COMMON
- Pin 6 - RIGHT AUDITION INSERT, FEED, HIGH
- Pin 7 - LEFT AUDITION INSERT, RETURN, SHIELD
- Pin 8 - AUDIO COMMON
- Pin 9 - LEFT AUDITION INSERT, RETURN, HIGH
- Pin 10 - RIGHT AUDITION INSERT, RETURN, SHIELD
- Pin 11 - AUDIO COMMON
- Pin 12 - RIGHT AUDITION INSERT, RETURN, HIGH



Key diagram showing back of typical 12-pin I/O connector plug, with pin numbers oriented as they would be seen while wiring. Beveled corners correspond to PCB mounted mating sockets.

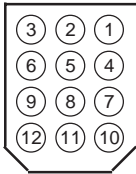

PGM, AUD, MONO, CR and STUDIO outputs are electronically balanced. If feeding an unbalanced load, use HIGH and SHIELD. Do not short LOW to SHIELD permanently

CUE OUTPUT is a line level output and will not drive a speaker directly.

### Program/Audition Out

(CT15, R-60 Mother Board load sheet dwg)

- Pin 1 - LEFT PROGRAM OUTPUT, SHIELD
- Pin 2 - LEFT PROGRAM OUTPUT, LOW
- Pin 3 - LEFT PROGRAM OUTPUT, HIGH
- Pin 4 - RIGHT PROGRAM OUTPUT, SHIELD
- Pin 5 - RIGHT PROGRAM OUTPUT, LOW
- Pin 6 - RIGHT PROGRAM OUTPUT, HIGH
- Pin 7 - LEFT AUDITION OUTPUT, SHIELD
- Pin 8 - LEFT AUDITION OUTPUT, LOW
- Pin 9 - LEFT AUDITION OUTPUT, HIGH
- Pin 10 - RIGHT AUDITION OUTPUT, SHIELD
- Pin 11 - RIGHT AUDITION OUTPUT, LOW
- Pin 12 - RIGHT AUDITION OUTPUT, HIGH

### Control Room

(CT16, R-60 Mother Board load sheet dwg)

- Pin 1 - LEFT CONTROL ROOM OUTPUT, SHIELD
- Pin 2 - LEFT CONTROL ROOM OUTPUT, LOW
- Pin 3 - LEFT CONTROL ROOM OUTPUT, HIGH
- Pin 4 - RIGHT CONTROL ROOM OUTPUT, SHIELD
- Pin 5 - RIGHT CONTROL ROOM OUTPUT, LOW
- Pin 6 - RIGHT CONTROL ROOM OUTPUT, HIGH
- Pin 7 - LEFT HEADPHONE OUTPUT, SHIELD
- Pin 8 - LEFT HEADPHONE OUTPUT, LOW
- Pin 9 - LEFT HEADPHONE OUTPUT, HIGH
- Pin 10 - RIGHT HEADPHONE OUTPUT, SHIELD
- Pin 11 - RIGHT HEADPHONE OUTPUT, LOW
- Pin 12 - RIGHT HEADPHONE OUTPUT, HIGH

### Control Room

(CT34, R-60 Mother Board load sheet dwg)

- Pin 1 - CUE SPEAKER OUTPUT, LOW, SHIELD
- Pin 2 - CUE SPEAKER OUTPUT, LOW
- Pin 3 - CUE SPEAKER OUTPUT, HIGH
- Pin 4 - CUE OUTPUT, SHIELD
- Pin 5 - CUE OUTPUT, LOW
- Pin 6 - CUE OUTPUT, HIGH
- Pin 7 - AUDIO COMMON
- Pin 8 - ON AIR RELAY, COMMON
- Pin 9 - ON AIR RELAY, NORMALLY OPEN
- Pin 10 - AUDIO COMMON
- Pin 11 - SPARE
- Pin 12 - SPARE

Key diagram showing back of typical 12-pin I/O connector plug, with pin numbers oriented as they would be seen while wiring. Beveled corners correspond to PCB mounted mating sockets.

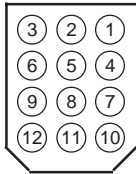

### Studio Control

(CT17, R-60 Mother Board load sheet dwg)

- Pin 1 - LEFT STUDIO OUTPUT, SHIELD
- Pin 2 - LEFT STUDIO OUTPUT, LOW
- Pin 3 - LEFT STUDIO OUTPUT, HIGH
- Pin 4 - RIGHT STUDIO OUTPUT, SHIELD
- Pin 5 - RIGHT STUDIO OUTPUT, LOW
- Pin 6 - RIGHT STUDIO OUTPUT, HIGH
- Pin 7 - MONO OUTPUT, SHIELD
- Pin 8 - MONO OUTPUT, LOW
- Pin 9 - MONO OUTPUT, HIGH
- Pin 10 - AUDIO COMMON
- Pin 11 - SPARE
- Pin 12 - SPARE

### Studio Control / Control Room External Inputs

(CT35, R-60 Mother Board load sheet dwg)

- Pin 1 - LEFT EXTERNAL ONE, SHIELD
- Pin 2 - LEFT EXTERNAL ONE, LOW
- Pin 3 - LEFT EXTERNAL ONE, HIGH
- Pin 4 - RIGHT EXTERNAL ONE, SHIELD
- Pin 5 - RIGHT EXTERNAL ONE, LOW
- Pin 6 - RIGHT EXTERNAL ONE, HIGH
- Pin 7 - LEFT EXTERNAL TWO, SHIELD
- Pin 8 - LEFT EXTERNAL TWO, LOW
- Pin 9 - LEFT EXTERNAL TWO, HIGH
- Pin 10 - RIGHT EXTERNAL TWO, SHIELD
- Pin 11 - RIGHT EXTERNAL TWO, LOW
- Pin 12 - RIGHT EXTERNAL TWO, HIGH

### DMP-60 Input

(CT1, DMP-60 load sheet dwg)

- Pin 1 - MICROPHONE 1 INPUT, SHIELD
- Pin 2 - MICROPHONE 1 INPUT, LOW
- Pin 3 - MICROPHONE 1 INPUT, HIGH
- Pin 4 - AUDIO COMMON
- Pin 5 - NO CONNECTION
- Pin 6 - NO CONNECTION
- Pin 7 - MICROPHONE 2 INPUT, SHIELD
- Pin 8 - MICROPHONE 2 INPUT, LOW
- Pin 9 - MICROPHONE 2 INPUT, HIGH
- Pin 10 - AUDIO COMMON
- Pin 11 - NO CONNECTION
- Pin 12 - NO CONNECTION

Key diagram showing back of typical 12-pin I/O connector plug, with pin numbers oriented as they would be seen while wiring. Beveled corners correspond to PCB mounted mating sockets.

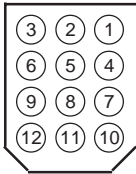

### DMP-60 Output

(CT2, DMP-60 load sheet dwg)

- Pin 1 - MICROPHONE 1 OUTPUT, SHIELD
- Pin 2 - AUDIO COMMON
- Pin 3 - MICROPHONE 1 OUTPUT, HIGH
- Pin 4 - MICROPHONE 1 OUTPUT, SHIELD
- Pin 5 - AUDIO COMMON
- Pin 6 - MICROPHONE 1 OUTPUT, HIGH
- Pin 7 - MICROPHONE 2 OUTPUT, SHIELD
- Pin 8 - AUDIO COMMON
- Pin 9 - MICROPHONE 2 OUTPUT, HIGH
- Pin 10 - MICROPHONE 2 OUTPUT, SHIELD
- Pin 11 - AUDIO COMMON
- Pin 12 - MICROPHONE 2 OUTPUT, HIGH

### LS-60 Inputs 1 & 2

(CT3, LS-60 load sheet dwg)

- Pin 1 - LINE 2 LEFT INPUT, SHIELD
- Pin 2 - LINE 2 LEFT INPUT, LOW
- Pin 3 - LINE 2 LEFT INPUT, HIGH
- Pin 4 - LINE 2 RIGHT INPUT, SHIELD
- Pin 5 - LINE 2 RIGHT INPUT, LOW
- Pin 6 - LINE 2 RIGHT INPUT, HIGH
- Pin 7 - LINE 1 LEFT INPUT, SHIELD
- Pin 8 - LINE 1 LEFT INPUT, LOW
- Pin 9 - LINE 1 LEFT INPUT, HIGH
- Pin 10 - LINE 1 RIGHT INPUT, SHIELD
- Pin 11 - LINE 1 RIGHT INPUT, LOW
- Pin 12 - LINE 1 RIGHT INPUT, HIGH

### LS-60 Inputs 3 & 4

(CT2, LS-60 load sheet dwg)

- Pin 1 - LINE 4 LEFT INPUT, SHIELD
- Pin 2 - LINE 4 LEFT INPUT, LOW
- Pin 3 - LINE 4 LEFT INPUT, HIGH
- Pin 4 - LINE 4 RIGHT INPUT, SHIELD
- Pin 5 - LINE 4 RIGHT INPUT, LOW
- Pin 6 - LINE 4 RIGHT INPUT, HIGH
- Pin 7 - LINE 3 LEFT INPUT, SHIELD
- Pin 8 - LINE 3 LEFT INPUT, LOW
- Pin 9 - LINE 3 LEFT INPUT, HIGH
- Pin 10 - LINE 3 RIGHT INPUT, SHIELD
- Pin 11 - LINE 3 RIGHT INPUT, LOW
- Pin 12 - LINE 3 RIGHT INPUT, HIGH

Key diagram showing back of typical 12-pin I/O connector plug, with pin numbers oriented as they would be seen while wiring. Beveled corners correspond to PCB mounted mating sockets.

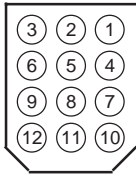

### LS-60 Inputs 5 & 6

(CT1, LS-60 load sheet dwg)

- Pin 1 - LINE 6 LEFT INPUT, SHIELD
- Pin 2 - LINE 6 LEFT INPUT, LOW
- Pin 3 - LINE 6 LEFT INPUT, HIGH
- Pin 4 - LINE 6 RIGHT INPUT, SHIELD
- Pin 5 - LINE 6 RIGHT INPUT, LOW
- Pin 6 - LINE 6 RIGHT INPUT, HIGH
- Pin 7 - LINE 5 LEFT INPUT, SHIELD
- Pin 8 - LINE 5 LEFT INPUT, LOW
- Pin 9 - LINE 5 LEFT INPUT, HIGH
- Pin 10 - LINE 5 RIGHT INPUT, SHIELD
- Pin 11 - LINE 5 RIGHT INPUT, LOW
- Pin 12 - LINE 5 RIGHT INPUT, HIGH

### LS-60 Output

(CT4, LS-60 load sheet dwg)

- Pin 1 - LEFT OUTPUT, SHIELD
- Pin 2 - LEFT OUTPUT, LOW
- Pin 3 - LEFT OUTPUT, HIGH
- Pin 4 - RIGHT OUTPUT, SHIELD
- Pin 5 - RIGHT OUTPUT, LOW
- Pin 6 - RIGHT OUTPUT, HIGH
- Pin 7 - AUDIO COMMON
- Pin 8 - NO CONNECTION
- Pin 9 - NO CONNECTION
- Pin 10 - AUDIO COMMON
- Pin 11 - NO CONNECTION
- Pin 12 - NO CONNECTION

**USER NOTE:** The 1Kohm series resistors on the TR-60 card have been selected to allow a wide range of operating voltages, from 5 to 24 volts. For this reason, the LEDs may appear dim when operated from 5 volts. If you will be operating the LEDs from 5 volts, and do not plan on running them at 24 volts, you may change the series resistors to 470 ohm, 1/4 watt devices, to increase LED brightness.

**CAUTION:** if 470 ohm, 1/4 watt resistors are installed, and the unit is then hooked up to a 24 volt source, the resistors will attempt to dissipate over 1 watt of power, and will burn up. Do not make this change unless you are sure that you will be using 5 volts to run the LEDs. If you are not sure of the voltage, measure it first.

### Tape Remote Switches 1-3

(CT1-CT14, R-60 Mother Board load sheet dwg)-  
(CT1-CT6, R-60 Ext Mother Board load sheet dwg)

- Pin 1 - SWITCH 1, LED CATHODE
- Pin 2 - SWITCH 2, LED CATHODE
- Pin 3 - SWITCH 3, LED CATHODE
- Pin 4 - SWITCH 1, LED ANODE
- Pin 5 - SWITCH 2, LED ANODE
- Pin 6 - SWITCH 3, LED ANODE
- Pin 7 - SWITCH 1, COMMON
- Pin 8 - SWITCH 2, COMMON
- Pin 9 - SWITCH 3, COMMON
- Pin 10 - SWITCH 1, NORMALLY OPEN
- Pin 11 - SWITCH 2, NORMALLY OPEN
- Pin 12 - SWITCH 3, NORMALLY OPEN

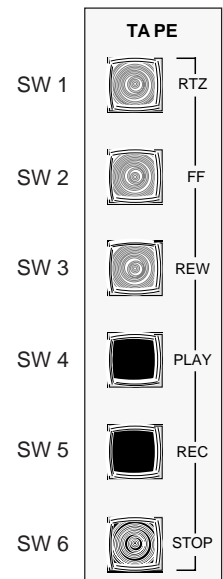

Key diagram showing back of typical 12-pin I/O connector plug, with pin numbers oriented as they would be seen while wiring. Beveled corners correspond to PCB mounted mating sockets.

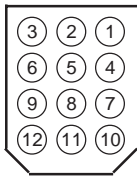

The SP-60 module does not connect directly to the telephone line. It must be connected to a telephone hybrid.

**Tape Remote Switches 4-6**

(CT19-CT32, R-60 Mother Board load sheet dwg)-  
(CT7-CT12, R-60 Ext Mother Board load sheet dwg)

- Pin 1 - SWITCH 4, LED CATHODE
- Pin 2 - SWITCH 5, LED CATHODE
- Pin 3 - SWITCH 6, LED CATHODE
- Pin 4 - SWITCH 4, LED ANODE
- Pin 5 - SWITCH 5, LED ANODE
- Pin 6 - SWITCH 6, LED ANODE
- Pin 7 - SWITCH 4, COMMON
- Pin 8 - SWITCH 5, COMMON
- Pin 9 - SWITCH 6, COMMON
- Pin 10 - SWITCH 4, NORMALLY OPEN
- Pin 11 - SWITCH 5, NORMALLY OPEN
- Pin 12 - SWITCH 6, NORMALLY OPEN

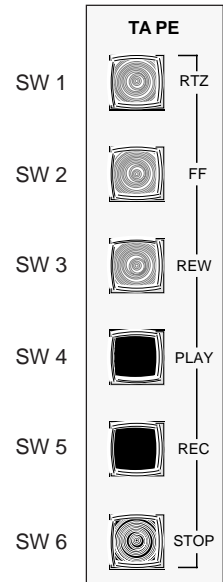

**Simple Phone**

(CT1-CT14, R-60 Mother Board load sheet dwg)

- Pin 1 - FROM CALLER ONE, SHIELD
- Pin 2 - FROM CALLER ONE, LOW
- Pin 3 - FROM CALLER ONE, HIGH
- Pin 4 - AUDIO COMMON
- Pin 5 - SPARE, LOW
- Pin 6 - SPARE, HIGH
- Pin 7 - TO CALLER ONE, SHIELD
- Pin 8 - TO CALLER ONE, LOW
- Pin 9 - TO CALLER ONE, HIGH
- Pin 10 - AUDIO COMMON
- Pin 11 - SPARE, LOW
- Pin 12 - SPARE, HIGH

**Simple Phone**

(CT19-CT32, R-60 Mother Board load sheet dwg)-  
(CT7-CT12, R-60 Ext Mother Board load sheet dwg)

- Pin 1 - NO CONNECTION
- Pin 2 - NO CONNECTION
- Pin 3 - NO CONNECTION
- Pin 4 - MACHINE COMMON
- Pin 5 - STOP
- Pin 6 - START
- Pin 7 - NO CONNECTION
- Pin 8 - NO CONNECTION
- Pin 9 - NO CONNECTION
- Pin 10 - NO CONNECTION
- Pin 11 - +5V LOGIC SUPPLY (FUSED)
- Pin 12 - DIGITAL COMMON

## **LOGIC FOLLOW OPTION**

The R-60 Logic Follow option allows line input modules to interface with two external source machines (tape players, cart machines, CD players, etc.), each at different location. The machine being controlled is determined by the A/B source select switch at the top of the module. The option consists of a printed circuit board (or boards) mounted in the console's meterbridge. Source machines are connected to the logic follow card and it in turn is connected to the input module's control ports. Pinout information is as follows:

### **Logic Follow**

(CT1, LF-60 load sheet dwg)

- Pin 1 - REMOTE ON
- Pin 2 - REMOTE OFF
- Pin 3 - ON TALLY
- Pin 4 - MACHINE COMMON
- Pin 5 - REMOTE STOP
- Pin 6 - REMOTE START
- Pin 7 - READY
- Pin 8 - COUGH
- Pin 9 - TALKBACK
- Pin 10 - A/B LOGIC FOLLOW
- Pin 11 - +5V LOGIC SUPPLY (FUSED)
- Pin 12 - DIGITAL COMMON

### **Logic Follow**

(CT2, LF-60 load sheet dwg)

- Pin 1 - A, REMOTE ON
- Pin 2 - A, REMOTE OFF
- Pin 3 - A, ON TALLY
- Pin 4 - A, MACHINE COMMON
- Pin 5 - A, REMOTE STOP
- Pin 6 - A, REMOTE START
- Pin 7 - A, READY
- Pin 8 - A, COUGH
- Pin 9 - A, TALKBACK
- Pin 10 - N.C.
- Pin 11 - A, +5V LOGIC SUPPLY (FUSED)
- Pin 12 - A, DIGITAL COMMON

### **Logic Follow**

(CT3, LF-60 load sheet dwg)

- Pin 1 - B, REMOTE ON
- Pin 2 - B, REMOTE OFF
- Pin 3 - B, ON TALLY
- Pin 4 - B, MACHINE COMMON
- Pin 5 - B, REMOTE STOP
- Pin 6 - B, REMOTE START
- Pin 7 - B, READY
- Pin 8 - B, COUGH
- Pin 9 - B, TALKBACK
- Pin 10 - N.C.
- Pin 11 - B, +5V LOGIC SUPPLY (FUSED)
- Pin 12 - B, DIGITAL COMMON

## COMPLETING THE INSTALLATION

### POWER SUPPLY

Mount the PS-6040 Power Supply, for the R-60 console, in a standard 19 inch equipment rack, keeping in mind that adequate ventilation is necessary to prevent heat build-up within the rack.

Once the supply is mounted, connect the power cable at the console end (the power supply connector is located inside the meterbridge area, near the right end of the console). Note that the cable plug has to be rotated until the locating pins match the connector on the console. Do not force the connector on; it attaches easily when properly aligned. Connect the cable to the power supply in the same manner.

Once the power supply installation is complete, check the power supply mounting and cabling before continuing.

### VU METER ALIGNMENT

With the console in place on the counter top, check the VU meters for static, power-off alignment. If any adjustment is needed, raise the hinged meter bridge and note the meter adjusters located in the rear center of the meters. Alignment is accomplished by using a small flat blade screw driver to turn the adjusting screws until the meter reading is correct. Note that the screw should always be turned clockwise, and that correct adjustment is made when the meter is brought UP to the correct mark from downscale. Also notice that the static zero position changes as the meter bridge is brought down to its normal position. Make small incremental adjustments and return the meterbridge to operating position between adjustments; continue this procedure until the meter static zeroes are correct with the meterbridge in position.

Note that the VU meter lamps are replaceable from the back of the meter.

Unless VU meters are noticeably mis-aligned, this procedure (which can be a lengthy process) is normally not required.

### CLOSING UP THE CONSOLE

Replace all individual modules by plugging them into the console mainframe one by one.

Once all of the modules are in place and the meterbridge is down, start replacing the screws that hold the modules in place. Don't tighten the screws until all are installed. With all the module screws started, install the three screws that hold down the meterbridge. When all of these screws are in place, tighten them.

Before connecting the console's AC power, turn all faders and level controls on the console and any monitor equipment connected to it down to minimum. In preparation for testing your installation, assign one channel to PGM and select PGM on the CR module.

The Power Supply AC connector may now be connected; this will turn on the console. At this point the VU meters should be lit, and the LEDs of any assign switches that are down should be lit. Each channel that has the local OFF feature programmed will have either its ON or OFF lamp lit. The CUE LEDs may be lit.

Turn the module you will begin testing with ON by pressing its ON button. The ON lamp should light. Make sure the channel is assigned to PGM and slowly move the fader up. You should see movement on the PGM meters, provided there is source material available for that channel. If you have trouble at this or any other point in the installation test, turn to the section on troubleshooting, at the end of the technical section of the manual.

Press the CUE button for that channel and slowly turn up the CUE level control on the CR module; if the channel has been programmed for CUE, you should hear the source material in the console's CUE speaker. Note that the channel fader and ON/OFF status have no effect on the volume of the CUE signal.

Assign the channel to AUD and those meters should also move. Check other channels. Turn the console's control room level control to the 2 o'clock position, and slowly turn up the control room monitor amplifier; your source material should become audible. Assign a channel to studio, via PGM or AUD, turn the console's studio level control to 2 o'clock, and turn the studio monitor amplifier up. You should now be able to hear your source material in the studio. (If your power amplifier does not have input level controls, use external pads to allow a comfortable listening level with the console monitor pots set at 2 o'clock; this will assure optimal L—R tracking).

Test the other channels, the headphone jack (BE CAREFUL: LOUD SOUNDS IN THE HEADPHONES CAN DAMAGE YOUR HEARING), the external CUE output, the MONO output, and the output to the external headphone amplifier, if one is used in your installation. Check any external logic functions.

## CALIBRATION TRIMPOTS

If you find it necessary to adjust individual trimpots on certain modules, note each R-60 console is supplied with an EXT-60 extender ribbon cable assembly that lets you work on an individual module while it is still connected to the console mainframe. See page 9-2 for more information.



---

# Console Operation

## Chapter Contents

Fader and Level Controls .....	4-1
Input and Output Assign Switches .....	4-1
Cueing.....	4-2
The Console Clock .....	4-2

The following notes are provided as an aid to understanding the console's operation. It is impossible, without writing a fair-sized text book, to cover all possible aspects of console use. The basics are as follows:

## FADER AND LEVEL CONTROLS

Normally, the faders will be run at the "in-hand" setting indicated by the dot on the fader scale, corresponding to about 12 dB below maximum fader setting. If you find yourself continually running a channel with the fader all the way to the top, the signal source is probably at too low a level. If the source has its own level control, that control may need to be turned up. Check with someone in charge if you're not sure about changing levels on other equipment.

Except for the headphone level, the console's output level controls will generally be run at a 2 o'clock setting. If this results in the control room speaker amplifier having to be run close to minimum, then turn the console's CR level control down some, or use external pads to attenuate the input signal to the power amplifier (ref: page 3-18).

Run the headphone level at a setting that is comfortable for you, but remember, **LOUD SOUNDS CAN DAMAGE YOUR HEARING**. Remember that a signal source may be at a higher level than you think it is. Be careful when switching channels ON or into CUE, if they will be heard in the headphones.

**NOTE The CUE level control also affects headphone volume for channels that are in CUE.**

## INPUT AND OUTPUT ASSIGN SWITCHES

The console is provided with three output busses: two stereo and one mono. The output busses are utilized by assigning input channel sources to them. For example: IN-60 module #5 is assigned to AUD if the AUD button for that channel pressed and the internal AUD LED is illuminated. Further, the AUD bus is selected by the studio when the AUD button on the SC-60 module is pressed and illuminated. Because of these two assigns, the channel 5 signal is heard in the studio speakers. This makes for a very flexible system for mixing and routing signal sources, if used creatively.

The PGM, or Program, bus is generally used for the on-air signal. For example, if the commercial spot recorded on the cart machine connected to channel 7 is supposed to be heard on air, then channel 7 should be assigned to PGM. On the other hand, if you have two studio mics that should both be on-air, those two channels should be assigned to PGM.

Even though, at a particular time, only one or two inputs may need to be assigned to the PGM bus, the other inputs may still be used. For example, while a channel 2 studio mic is on-air, and with a CD being played on channel 6, and also on-air as background to the studio mic, the operator can assign the tape recorder on channel 9 to the AUD, or Audition, bus, with AUD then being selected at the CR (Control Room), so the operator can locate a certain song on the tape without interfering with the on-air signal.

If you are doing a call-in show, the studio mic(s), and perhaps again some background music, can be assigned to the MONO, bus. The MONO output can be the audio that feeds the phone line back to the caller, so the caller can hear, over the telephone, all of the on-air signal except his or her own voice. Note also the optional Simple Phone™ module, which automatically handles call-ins.

The on-air signal from a modulation monitor or a high-quality tuner can be connected to the one of two EXT, or External, inputs of the CR (or SC [Studio Control]) module, to allow the operator (or the studio talent) to hear the on-air signal by using the EXT assign for that module.

## CUEING

In addition to the assignment features described above, the console has an additional mono bus called CUE that can be used by the operator when he or she needs to be sure that, for example, the cart machine on channel 6 is set to play the right jingle. Channel 6 CUE button is pushed, and the associated LED lights. The material on that channel appears in the headphones, and also left and/or right control room speaker, if so programmed. Meanwhile, the on-air signal is uninterrupted. Once the cart selection is verified, the CUE button is pressed again to take the channel out of CUE. At the proper time, the channel is then turned ON. If the external logic to the cart is connected to the module logic port, pushing the ON button can also start the cart machine. In addition, if CUE dropout is programmed for the channel, the CUE button doesn't have to be pressed to take the channel out of CUE; this will be accomplished automatically when the channel's ON button is pushed.

## THE CONSOLE CLOCK

### GENERAL DESCRIPTION

The R-60 console clock (18-input mainframes only) is a six-digit time-of-day clock with LED display designed for mounting in the console meterbridge. The clock is designed with CMOS logic circuits and an on board crystal-controlled time base oscillator. Numerous jumpers are provided on the clock circuit board to allow for various operational modes, including 12-hour, 24-hour, remote slave, and 60 Hz power line or 1Hz referenced timebase.

## **CONTROLS**

The clock is controlled by a trimmer and various switches. The trimmer is mounted on the main clock PCB, along with a pair of switches for setting the time.

The switches provided to set the clock are MODE (labeled "M") and SET (labeled "S"). From normal operating mode, press MODE once to make seconds flash, again to make minutes flash, again to make hours flash, and once more to return to normal operating mode. While seconds are flashing, press SET to reset the seconds to "00". While minutes or hours are flashing, press SET once to advance the time by one minute (or hour). Holding SET will allow the display setting to advance more quickly.

The trimmer serves to slightly alter the frequency of the quartz-controlled oscillator, which in turn causes the clock to run slightly slower or faster. In order to keep accurate time, the oscillator must run at 32.768 KHz, which is divided down internally to yield 1.0000 Hz to feed the counter chain. The oscillator is set to this frequency at the factory. However, due to the nature of quartz/crystal-controlled oscillators, there may be a slight change in the frequency of the oscillator during the first few months of operation as the crystal "ages." A minor readjustment of the trimmer will compensate for this effect. Should you find this necessary, a buffered output of the oscillator is available at pin #9 of IC #U22 to assist in making the adjustment.

---

# Module Controls

## Chapter Contents

IN-60 Input Module .....	5-2
CR-60 Control Room Module .....	5-3
SC-60 Studio Module .....	5-4
OM-60 Output Module .....	5-5
SP-60 Simple Phone™ Module .....	5-6
TR-60 Tape Remote Module .....	5-7
LS-60 Line Preselector .....	5-7

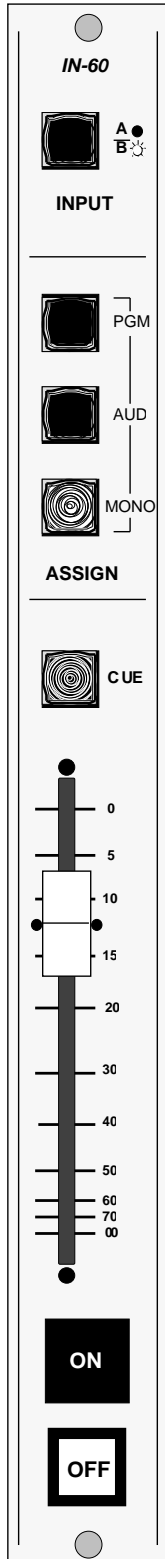

## IN-60 INPUT MODULE

**A/B SOURCE** - This switch (LED illuminated) selects between two electronically balanced stereo line inputs.

**ASSIGN** - These switches (LED illuminated) route channel signal to Program, Audition or Mono buses.

**CUE SWITCH** - (LED illuminated) sends the pre-fader signal to the CR module, where it interrupts the headphone signal. If the input module is so programmed (via dipswitch) it will also interrupt the left and/or right control room output. Depressing the cue switch activates this function. Cue is released when the cue button is pressed again, or can be dipswitch-programmed to automatically release when the channel ON button is activated.

**FADER** - A long-throw 104mm Penny & Giles precision conductive plastic fader is provided to assure the absolute maximum of reliability. Color-coded knobs are optionally available.

**ON/OFF SWITCHES** - The ON switch when depressed turns the channel signal on and can also start an external source machine, and be programmed to mute control room or studio speakers, as well as automatically restart the elapsed time timer. The OFF switch will turn off the module as well as external machines. The module's ON or OFF status can also be controlled from a remote location. The module provides either for a local (module-controlled) OFF lamp or a tally READY function where the source machine provides appropriate flashing and illuminating commands.

**PROGRAMMABLE FUNCTIONS** - These are activated from the module's channel ON button and may be preset via a dipswitch to mute control room or studio, restart the console timer, and activate the on-air tally relay.

**EXTERNAL CONTROL** - On, Off, Cough, Talkback and machine ready module functions may be controlled from a remote device such as a cart machine, CD player or talent mic control panel (when mic preamplifier submodule is utilized).

**GAIN TRIM** - Internal left and right gain trim potentiometers provide a 20dB control range (-6dB to +14dB), assuring compatibility with high level machines such as carts, or low level machines such as cassette players.

**INSERT POINT** - When a mic preamplifier submodule is utilized with the channel, its signal may be routed via the insert patch point to external mic processing equipment, such as EQ and compression. Note external signal processing may also be applied at the console's output bus insert points (Program, Audition and Mono).

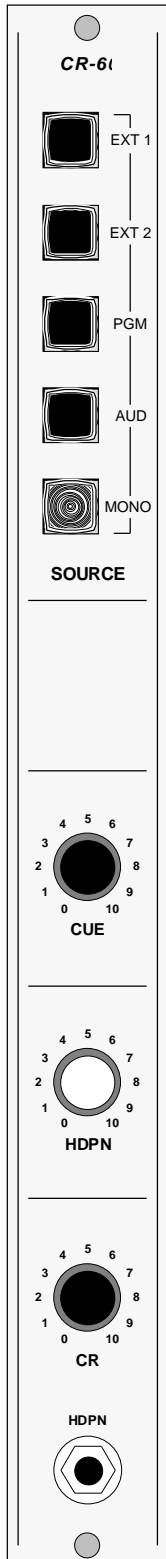

## CR-60 CONTROL ROOM MODULE

**SOURCE SELECTION** - This bank of LED-illuminated switches is used to determine the signal to be monitored in the control room. Choices include the three busses (PGM, AUD, MONO) or EXT 1 & 2 (electronically balanced stereo external line inputs; used for signals such as air, or may be wired to the line preselector located in the meterbridge).

**CUE** - This control determines the volume of the internal cue speaker mounted in the meterbridge, and also of the electronically balanced cue output. The cue signal interrupts the headphone circuit, and may also be dipswitch-programmed to interrupt the control room left and/or right speaker. The cue signal is automatically activated whenever an input module CUE switch is pressed. It is de-activated when the switch is pressed again, or may be automatically shut off when the module's channel ON switch is pressed (dipswitch-programmable).

The HDPN level control drives a headphone amplifier. This powerful built-in amp will satisfy all but the most demanding DJs, and eliminates the need for a separate external amplifier. The headphone signal is also available on an I/O port for interface to external power amp if desired. This port can also be used to feed signal to a guest headphone set.

**CR** - level control determines control room monitor level. CR output is electronically balanced to allow an interference-free feed to power amp.

**CONTROL ROOM MUTE** - CR mic module may be dipswitch selected to mute control room when the CR mic is ON. This mute function prevents control room feedback when monitor speakers are utilized.

**PROGRAMMABLE FUNCTIONS** - Cue normally interrupts HDPN monitor; it may also be programmed via dipswitch to interrupt CR left and/or right monitor. Thus a split feed CR interrupt with PGM on left and CUE on right is easily obtained.

**ON-AIR TALLY** - An on-air tally relay closure is provided; it may be activated whenever any of the control room microphones are open (dipswitch-programmable).

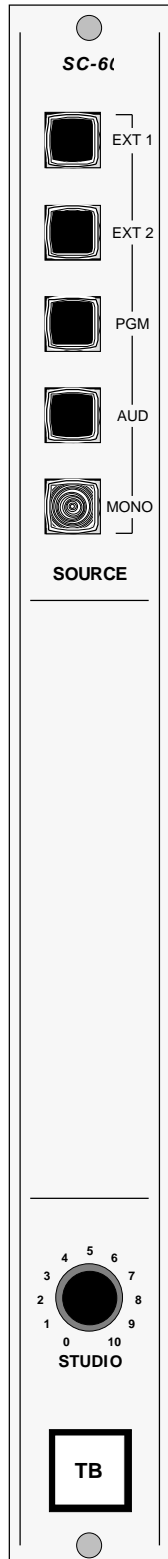

## SC-60 STUDIO CONTROL MODULE

**SOURCE SELECTION** - This bank of LED-illuminated switches is used to determine the signal to be monitored in the control room. Choices include the three busses (PGM, AUD, MONO) or EXT 1 & 2 (electronically balanced stereo external line inputs; used for signals such as air, or may be wired to the line preselector located in the meterbridge).

**TALKBACK BUTTON** - This momentary button feeds the announcer mic signal to studio output. Since the TB signal is internally routed from a pre-fader point on the announcer's mic channel, the TB button operates independently of the announcer mic channel ON/OFF status.

**STUDIO** - This control determines the studio monitor level. Studio output is electronically balanced and capable of +27dB levels to assure maximum interference rejection, plenty of headroom, and compatibility with power amplifier balanced input ports.

**STUDIO MUTE** - The studio mic module may be dipswitch-selected to mute studio whenever the studio mic is ON. This mute function prevents feedback when monitor speakers are utilized.

**MONO OUTPUT (internal)** - The console's mono output circuitry is located on the studio module printed circuit board. It may be used to feed signal to a caller hybrid, for a remote skimmer feed, or any application requiring a dedicated mono feed. An easily accessible internally mounted trimpot is provided for easy calibration. Like the PGM and AUD outputs, this signal is also electronically balanced to assure compatibility and noise free performance.

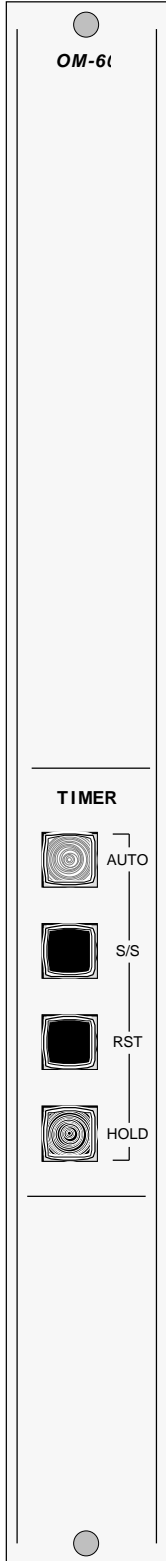

## OUTPUT MODULE

PROGRAM and AUDITION outputs are electronically balanced. Easily accessible internally mounted trimpots are provided for easy calibration and stereo balance.

INSERT POINTS are provided in PGM and AUD channels for station processing, such as EQ or compression. These inserts may be dipswitch-bypassed if desired.

TIMER control is provided by four switches (START/STOP, RESET, HOLD, and AUTO). The AUTO function will cause the timer to reset to zero and immediately begin counting upon activation of any pre-programmed input channel, thus greatly simplifying announcer workload and improving performance.



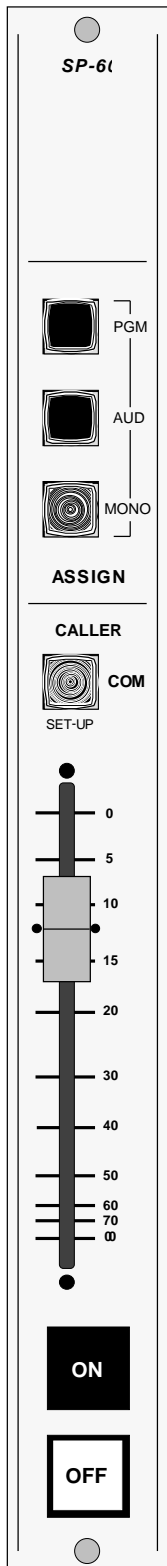

(Optional)

## SIMPLE PHONE™ INPUT (Optional)

The Simple Phone™ module is designed to automatically handle telephone call-in segments—either live and on-the-air or for later (recorded) use. Technically the module creates a mix-minus from any one of its three bus select buttons, receives all signals from the selected bus, feeds them to the caller, and then automatically routes those signals and the caller back to the bus without any feedback or feedback null circuitry.

When he wishes to handle a phone segment, the announcer hits the set-up button (COM), allowing direct communication (via the console cue system) for a preliminary interview between him and the caller. When ready to go on-air he hits the channel ON button, which automatically releases the setup function and routes the caller to air. If the segment is to be recorded for later use, the AUDITION or MONO bus would be selected (it's output would feed an external tape recorder). Because the bus assign switches on the Simple Phone™ module are electronically interlocked, the Program-to-Air selection will have been released to prevent a mishap. Note the module's channel ON/OFF buttons can be used to start and stop the remote machine.

**Recap:** the announcer selects the bus that he wants to operate from (PGM for live, AUD or MONO for record); he then sets up the call with the COMM setup button and when ready, energizes the channel ON buttons on the Simple Phone™ module and, if needed, the announcer mic channel to begin the segment. Everything else is automatic.

### CONFIGURATION NOTE - Talking to Callers Off-Air:

In order to talk to a caller off-air via the SP-60 module's COM button, the announcer's IN-60 input module's PCB-mounted programming dipswitch (SW1; see load sheet drawing page 7-1 and text page 3-4) must have position 7 ("TB") activated. This places the announcer's pre-fader, pre-on/off microphone signal onto the console's talkback monitor bus, where it may be picked up by the SP-60 module. **NOTE only one IN-60 module at a time can have this switch position activated.**

**INSTALLATION NOTE -** The SP-60 module does not connect directly to the telephone line. It must be connected to a telephone hybrid.

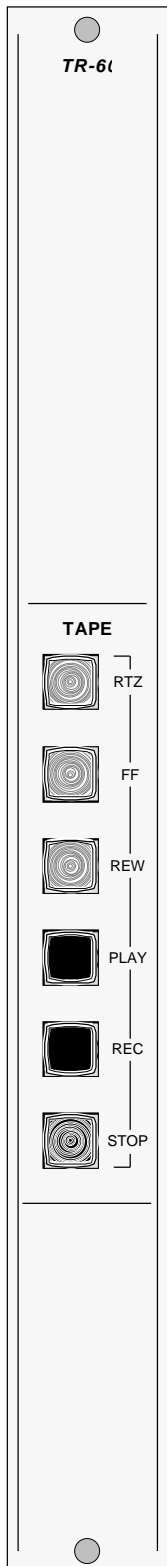

(Optional)

## TAPE REMOTE (Optional)

Six control buttons are provided; these can be configured as a full-function tape remote (FF-1 version; shown) or three pairs of Start/Stop buttons (SS-3 version). There is provision for LED illumination of each button from its external source machine (see schematic, page 6-5).

## LINE PRESELECTOR (not shown)

The LS-60 line preselector, mounted in the console meterbridge, comes standard with every R-60 console (18-input mainframes also have room for one optionally available additional preselector). The preselector is a bank of six switches that selects one of six stereo line inputs for routing to any input module or monitor module (CR-60 or SC-60) external line input. It is used to expand the input source capability of the console.

---

# Schematics

## Chapter Contents

IN-60 Input .....	6-2
DMP-60 Dual Mic Preamp .....	6-5
SP-60 Simple Phone™ .....	6-6
TR-60 Tape Remote .....	6-9
OM-60 Output .....	6-10
CR-60 Control Room .....	6-11
SC-60 Studio Control .....	6-14
TM-6 timer .....	6-17
CLK-5 clock .....	6-18
PS-6040 Power Supply .....	6-19
LF-60 Logic Follow .....	6-20
LS-60 Line Select .....	6-21

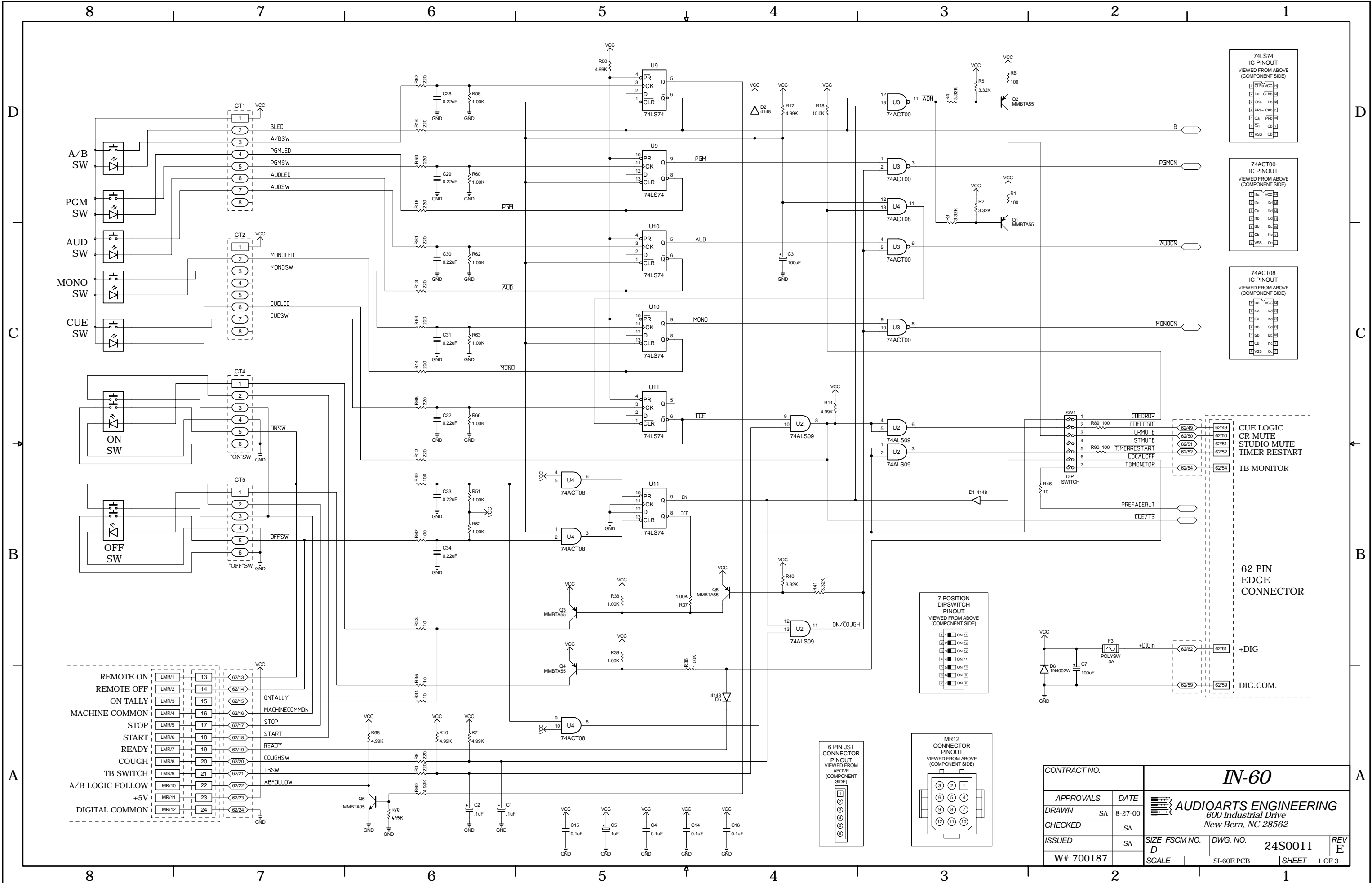

IN-60 Input Module Schematic - Sheet 1 of 3

CONTRACT NO.		<b>IN-60</b>		
APPROVALS	DATE	<b>AUDIOARTS ENGINEERING</b> 600 Industrial Drive New Bern, NC 28562		
DRAWN SA	8-27-00			
CHECKED SA				
ISSUED SA				
W# 700187	SCALE	SIZE D	FSCM NO.	DWG. NO. 24S0011
			SI-60E PCB	SHEET 1 OF 3

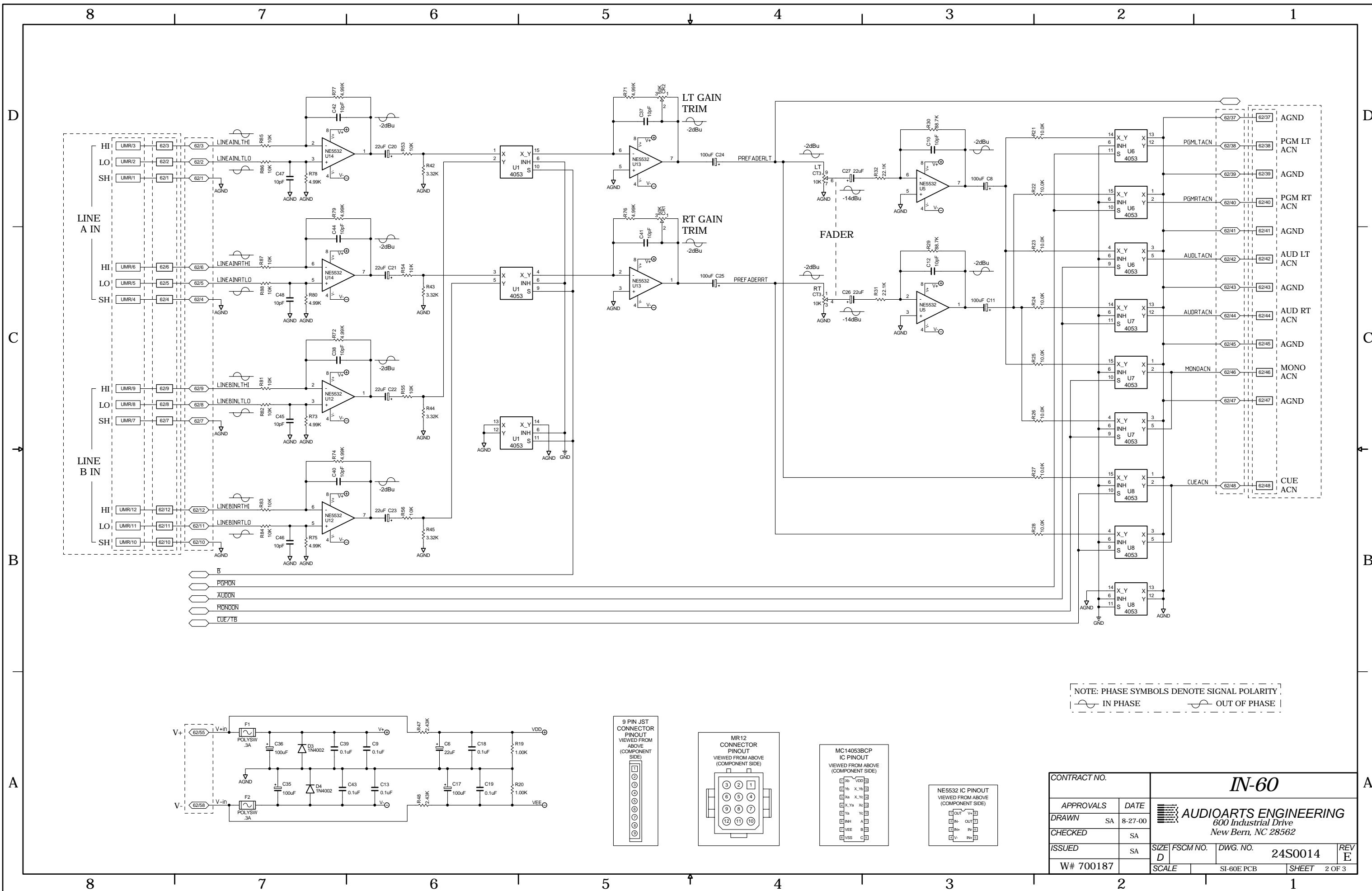

CONTRACT NO.		<b>IN-60</b>			
APPROVALS	DATE	<b>AUDIOARTS ENGINEERING</b> 600 Industrial Drive New Bern, NC 28562			
DRAWN SA	8-27-00				
CHECKED	SA	SIZE	FSCM NO.	DWG. NO.	REV
ISSUED	SA	D		24S0014	E
W# 700187		SCALE	SI-60E PCB	SHEET	2 OF 3

IN-60 Input Module Schematic - Sheet 2 of 3

# EDGE CONNECTOR BUSS CHART

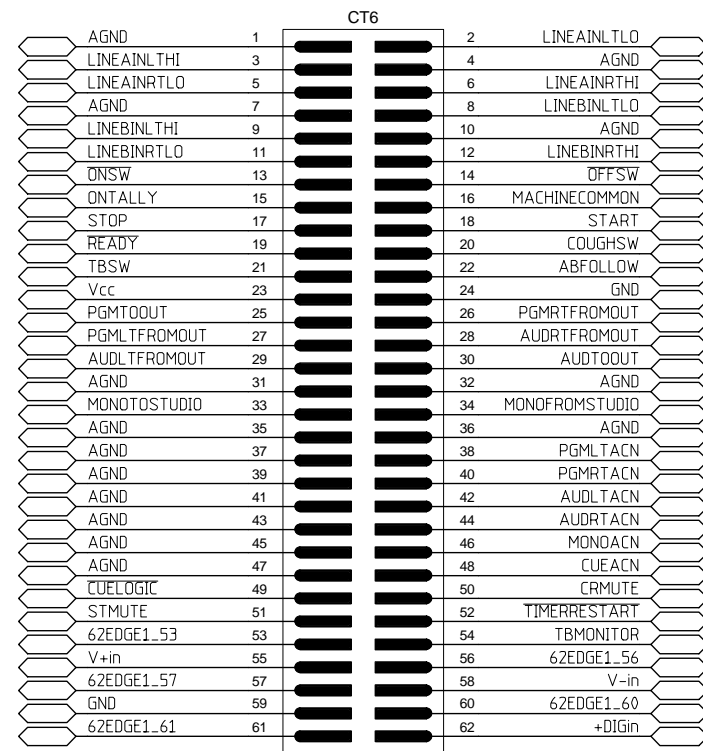

CONTRACT NO.		<b>IN-60</b>			
APPROVALS	DATE	<b>AUDIOARTS ENGINEERING</b> 600 Industrial Drive New Bern, NC 28562			
DRAWN SA	8-27-00				
CHECKED	SA	SIZE	FSCM NO.	DWG. NO.	REV
ISSUED	SA	B		24S0015	E
W# 700187		SCALE	SI-60E PCB	SHEET	3 OF 3

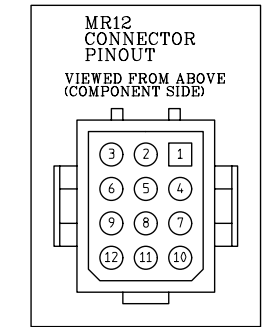
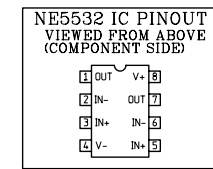
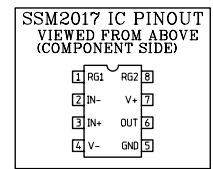
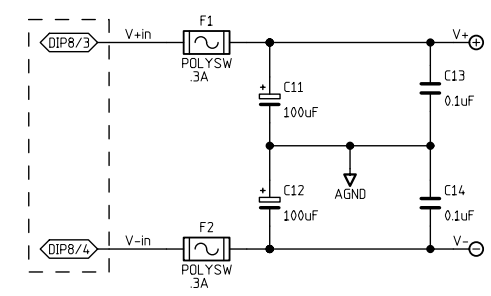
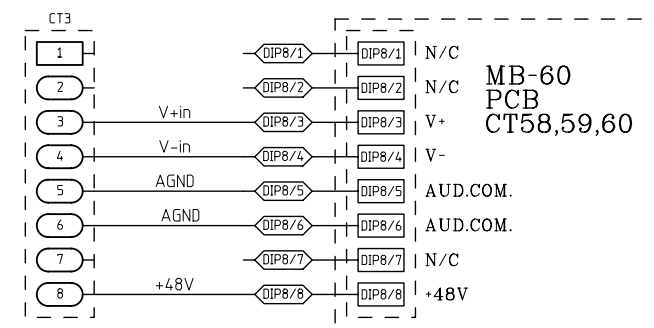
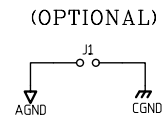
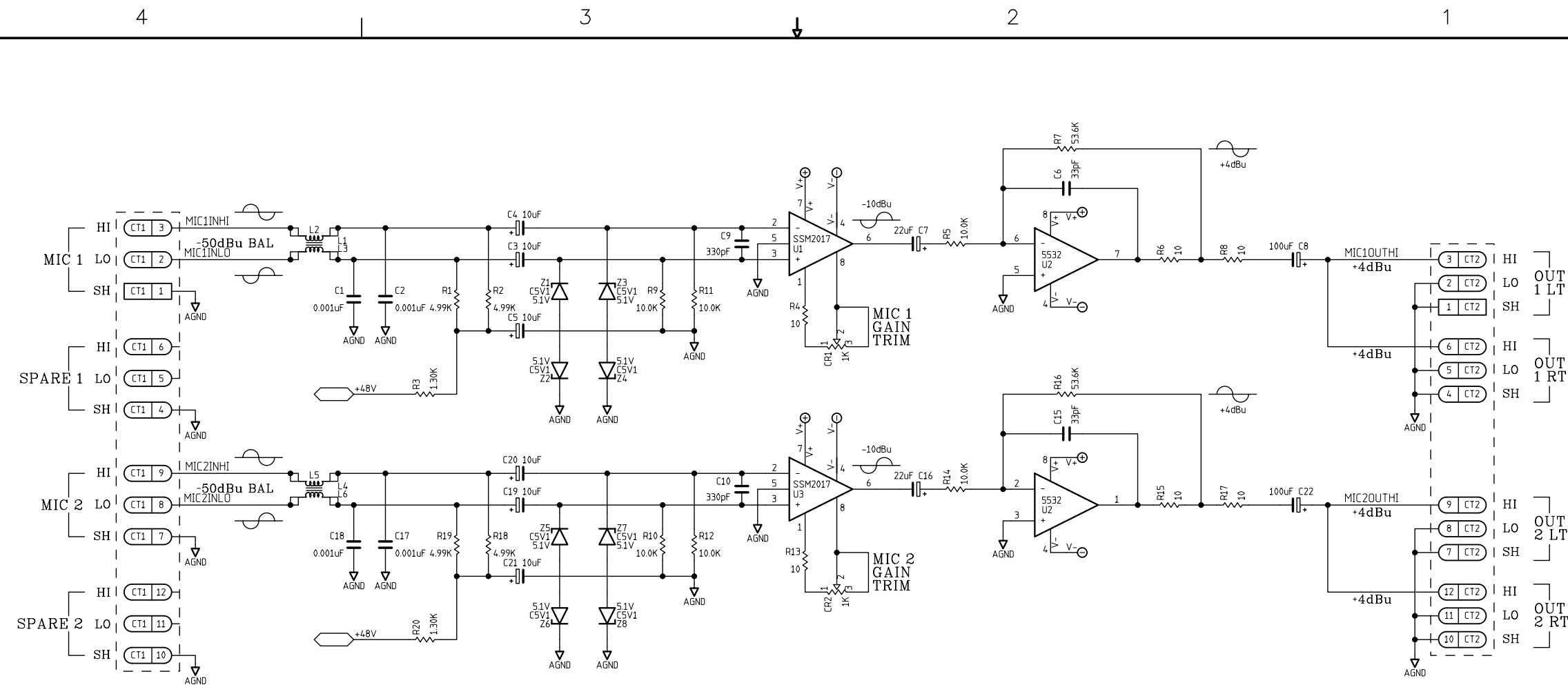

NOTE: PHASE SYMBOLS DENOTE SIGNAL POLARITY  
 IN PHASE      OUT OF PHASE

CONTRACT NO.		<b>DMP-60</b>	
APPROVALS	DATE	AUDIOARTS ENGINEERING	
DRAWN SA	9-17-99	600 Industrial Drive New Bern, NC 28562	
CHECKED		SIZE C	FSCM NO.
ISSUED		DWG. NO.	24S0026
W* 700201	SCALE	DMP-60B PCB	SHEET 1 OF 1

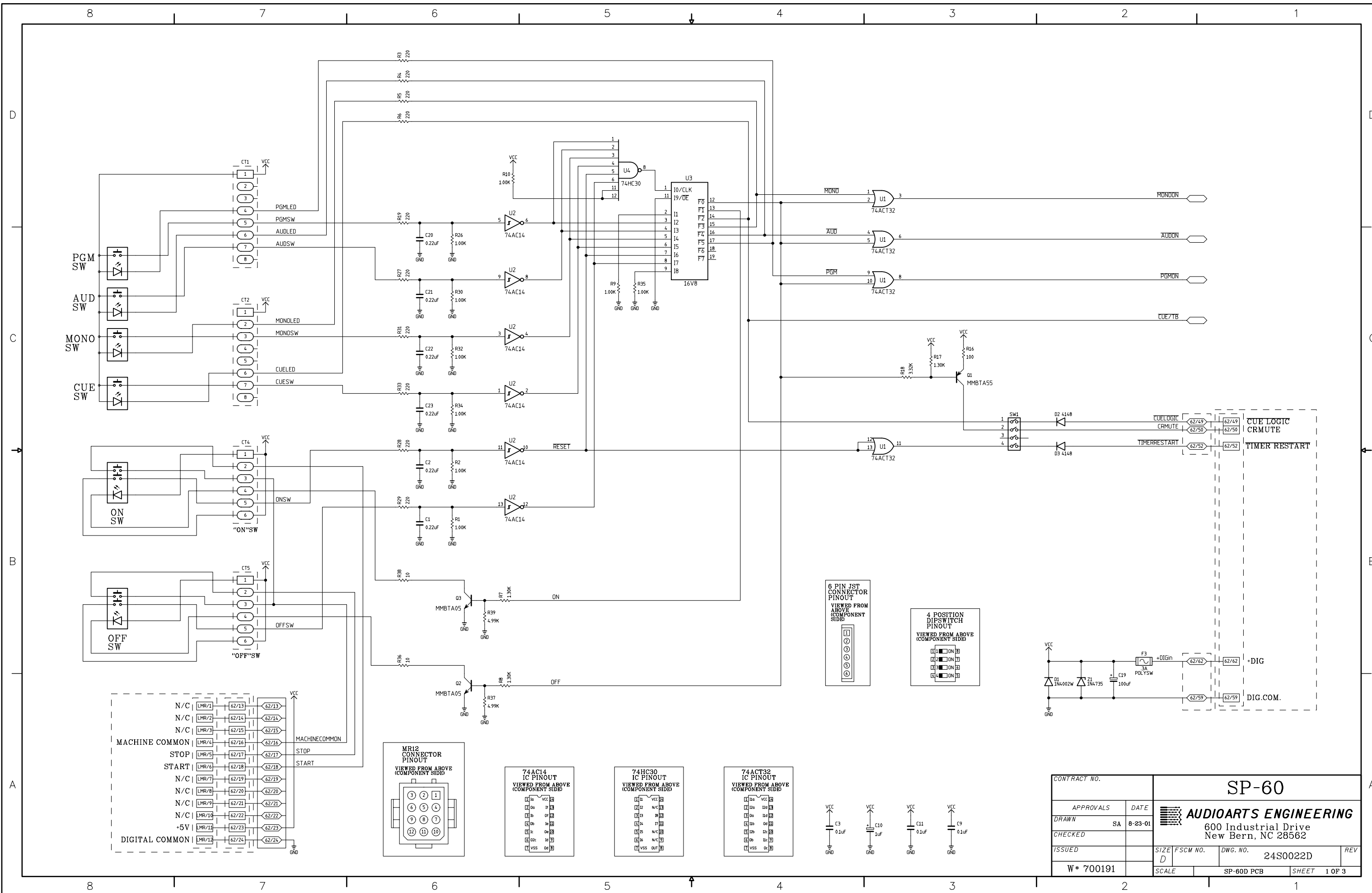

SP-60 Simple Phone Module Schematic - Sheet 1 of 3

CONTRACT NO.		<b>SP-60</b>	
APPROVALS	DATE	<b>AUDIOARTS ENGINEERING</b> 600 Industrial Drive New Bern, NC 28562	
DRAWN	SA 8-23-01		
CHECKED		SIZE	FSCM NO.
ISSUED		D	24S0022D
W # 700191		SCALE	SP-60D PCB
			SHEET 1 OF 3



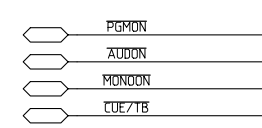
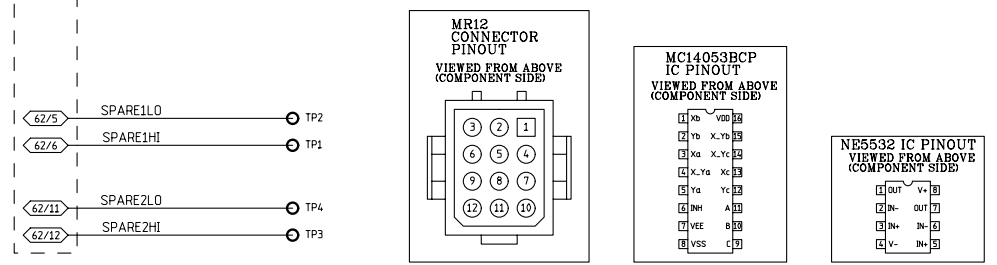
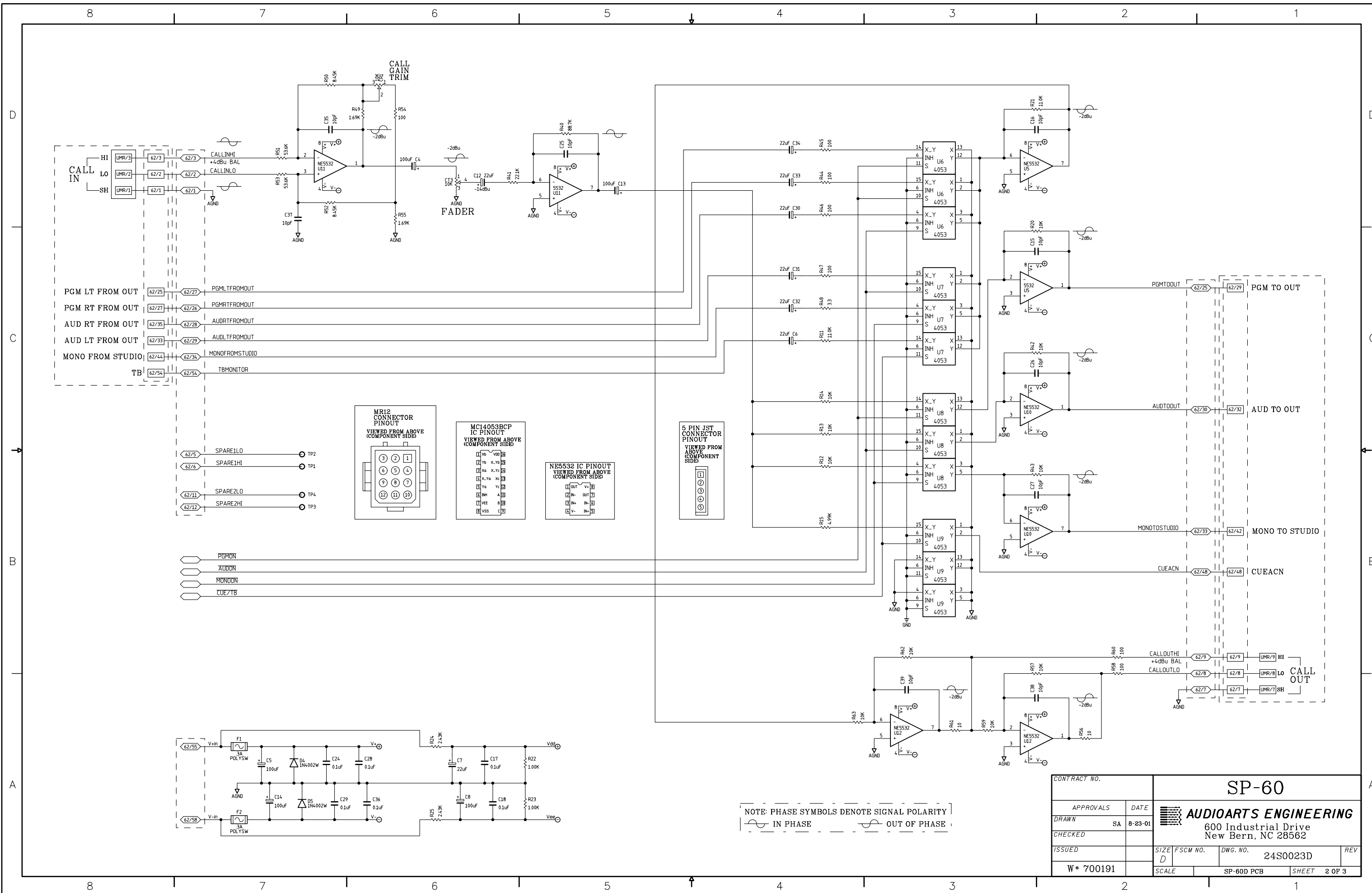

NOTE: PHASE SYMBOLS DENOTE SIGNAL POLARITY  
 IN PHASE  
 OUT OF PHASE

CONTRACT NO.		SP-60	
APPROVALS	DATE	AUDIOARTS ENGINEERING	
DRAWN SA	8-23-01	600 Industrial Drive New Bern, NC 28562	
CHECKED		SIZE D	FSCM NO. 24S0023D
ISSUED		DWG. NO.	REV
W # 700191		SCALE	SP-60D PCB SHEET 2 OF 3

## EDGE CONNECTOR BUSS CHART

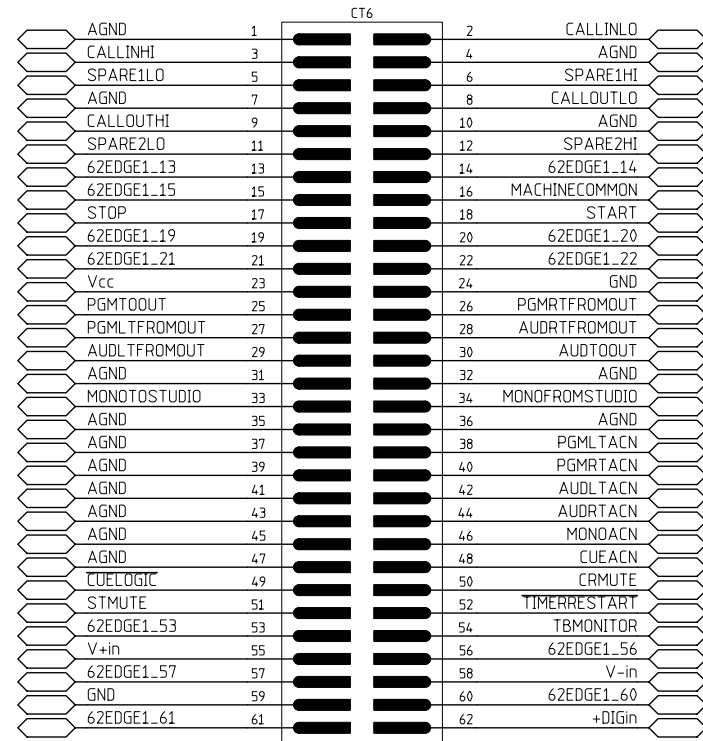

CONTRACT NO.		<b>SP-60</b>			
APPROVALS	DATE	<b>AUDIOARTS ENGINEERING</b> 600 Industrial Drive New Bern, NC 28562			
DRAWN SA	8-23-01				
CHECKED		SIZE	FSCM NO.	DWG. NO.	REV
ISSUED		B		24S0024D	-
W* 700191		SCALE	SP-60D PCB	SHEET	3 OF 3

4 3 2 1

D  
C  
B  
A

D  
C  
B  
A

### EDGE CONNECTOR BUSS CHART

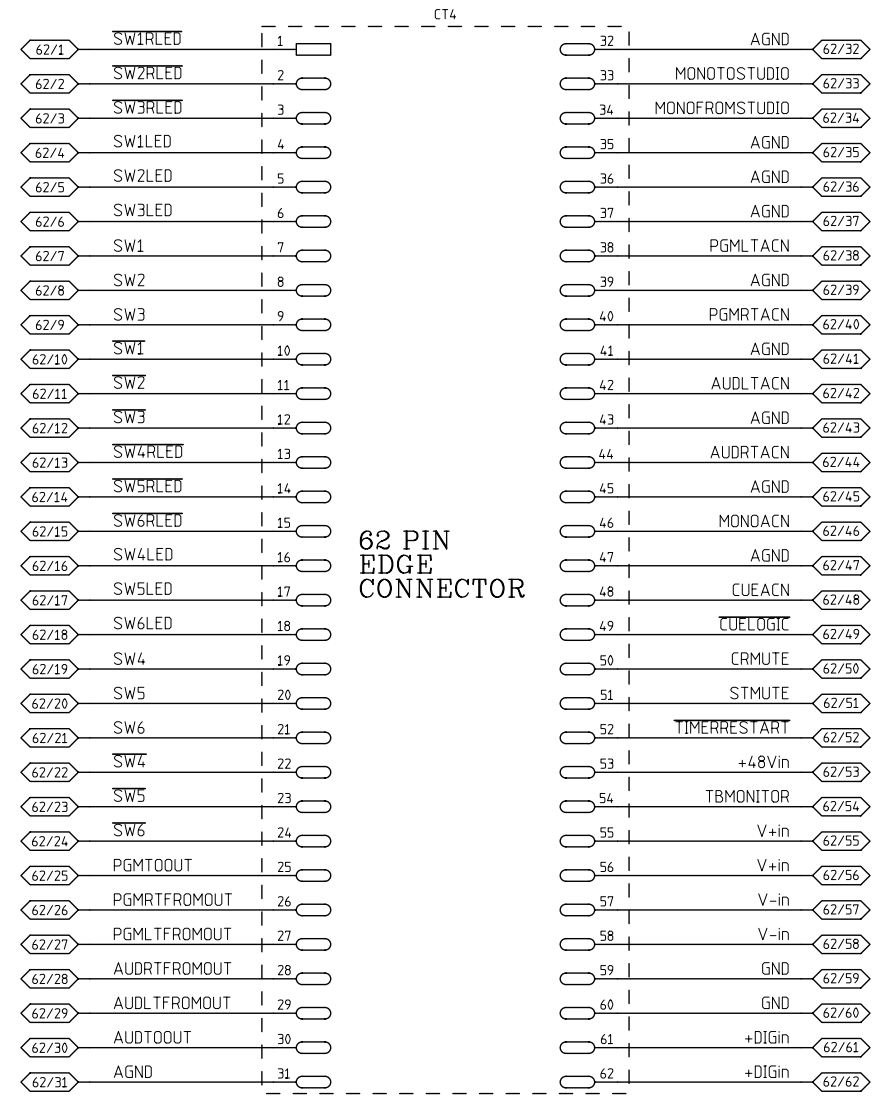
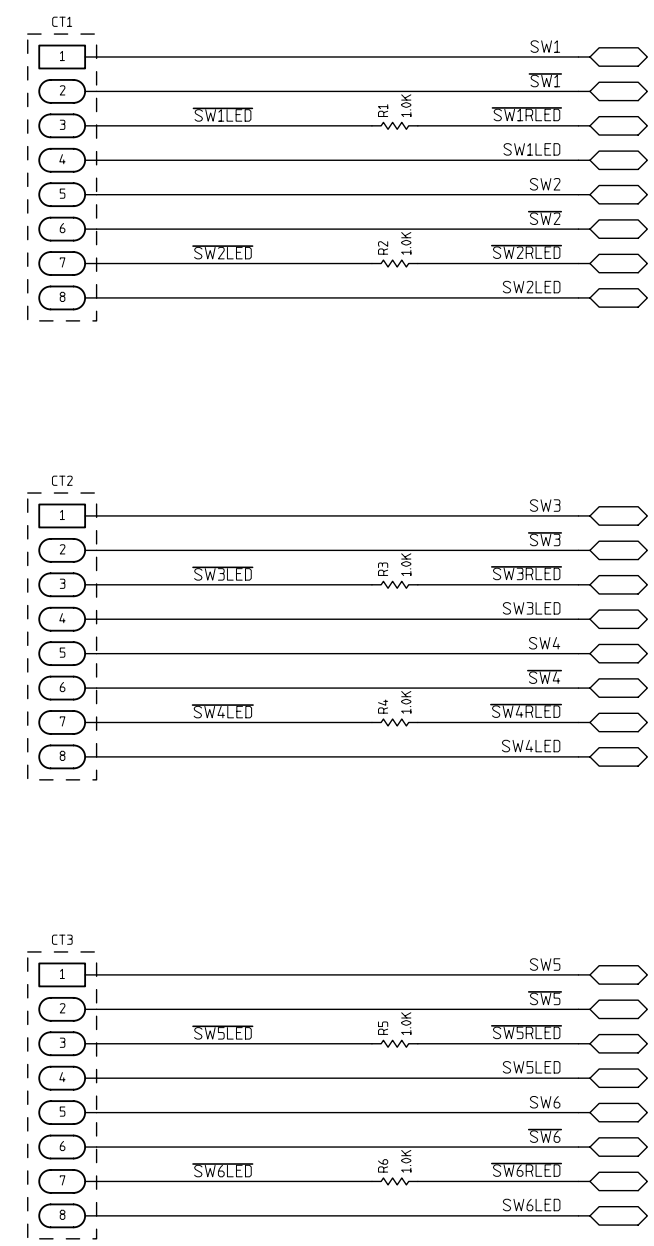

62 PIN  
EDGE  
CONNECTOR

AGND  
AGND  
AGND

4 3 2 1

CONTRACT NO.		TR-60	
APPROVALS	DATE	<b>AUDIOARTS ENGINEERING</b> 600 Industrial Drive New Bern, NC 28562	
DRAWN SA	9-17-99		
CHECKED		SIZE C	FSCM NO.
ISSUED		DWG. NO.	24S0032
W* 700192		SCALE	TR-60A PCB
		SHEET	1 OF 1

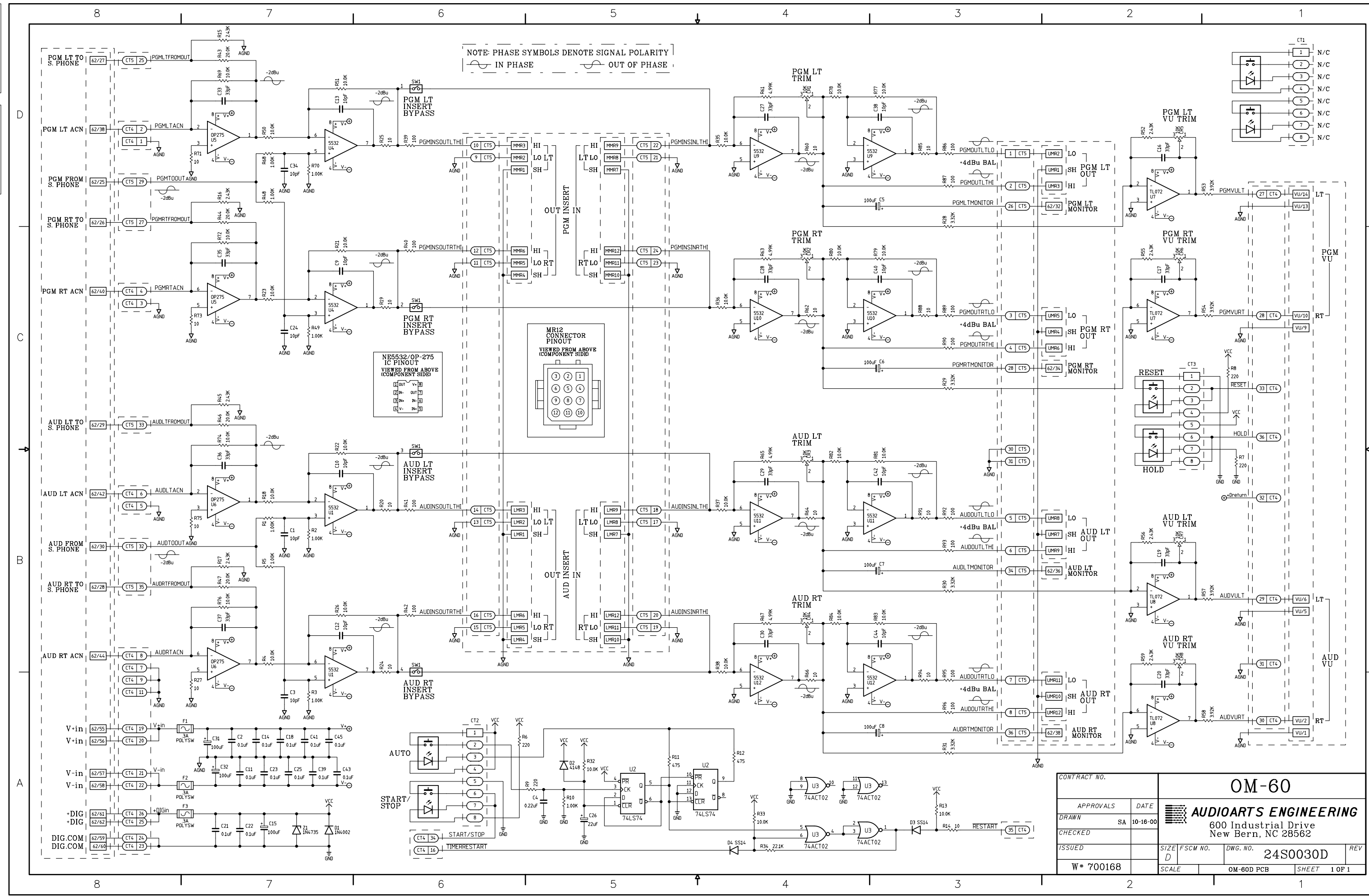
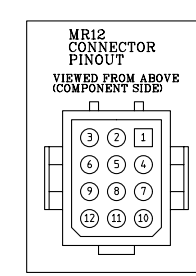
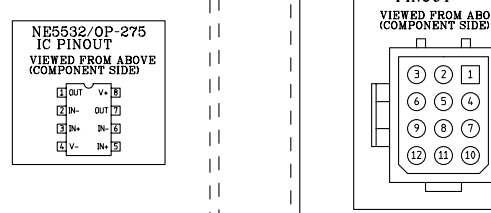
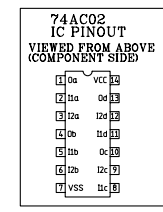

CONTRACT NO.		<b>OM-60</b>	
APPROVALS	DATE	<b>AUDIOARTS ENGINEERING</b> 600 Industrial Drive New Bern, NC 28562	
DRAWN	SA 10-16-00		
CHECKED		SIZE	FSCM NO.
ISSUED		DWG. NO.	24S0030D
W# 700168		SCALE	OM-60D PCB
			SHEET 1 OF 1

OM-60 Output Module Schematic - Sheet 1 of 1

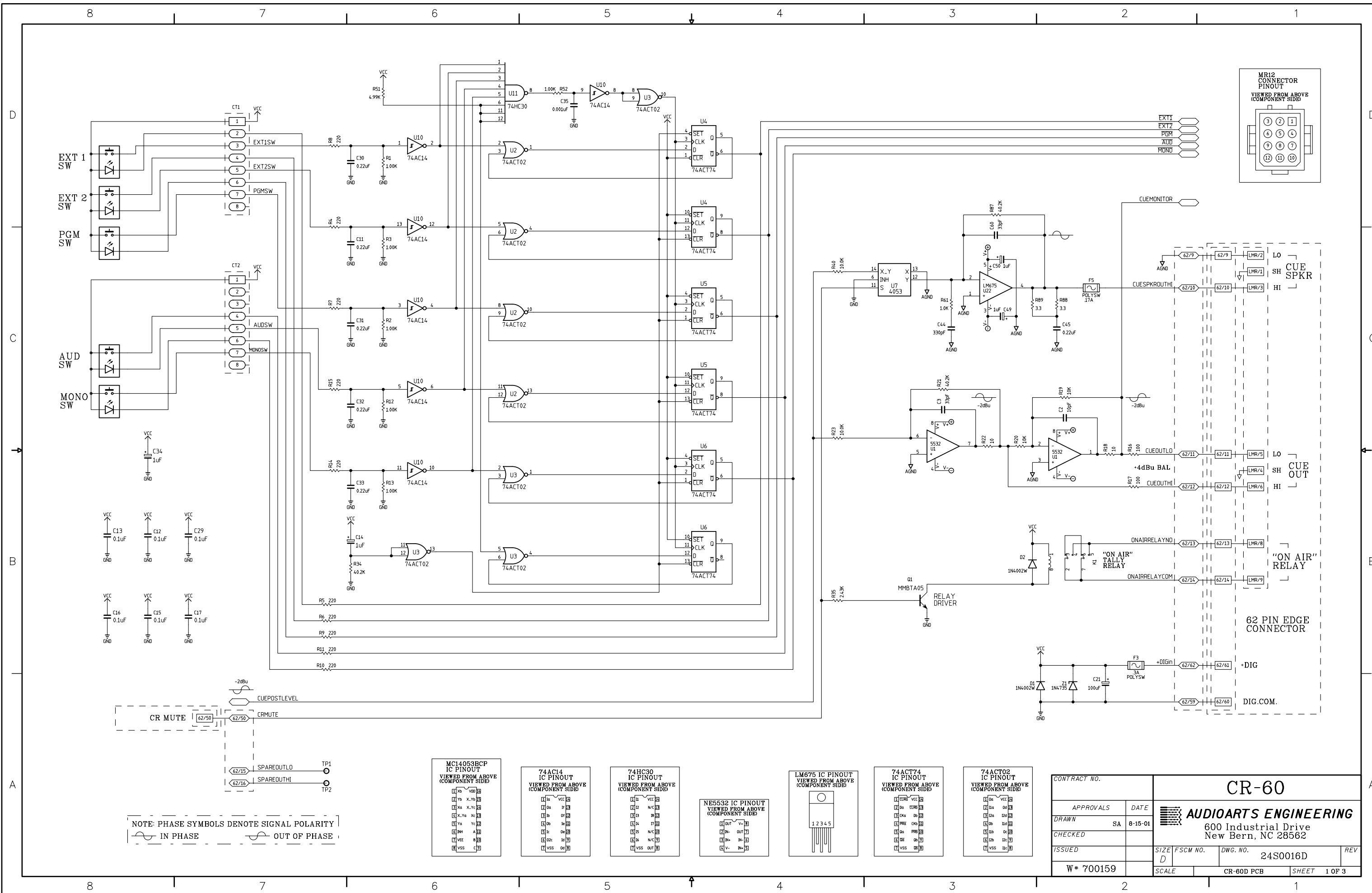

CR-60 Control Room Module Schematic - Sheet 1 of 3

CONTRACT NO.		CR-60	
APPROVALS	DATE	AUDIOARTS ENGINEERING	
DRAWN SA	8-15-01	600 Industrial Drive New Bern, NC 28562	
CHECKED		SIZE D	FSCM NO. 24S0016D
ISSUED		DWG. NO.	24S0016D
W# 700159		SCALE	CR-60D PCB
			SHEET 1 OF 3

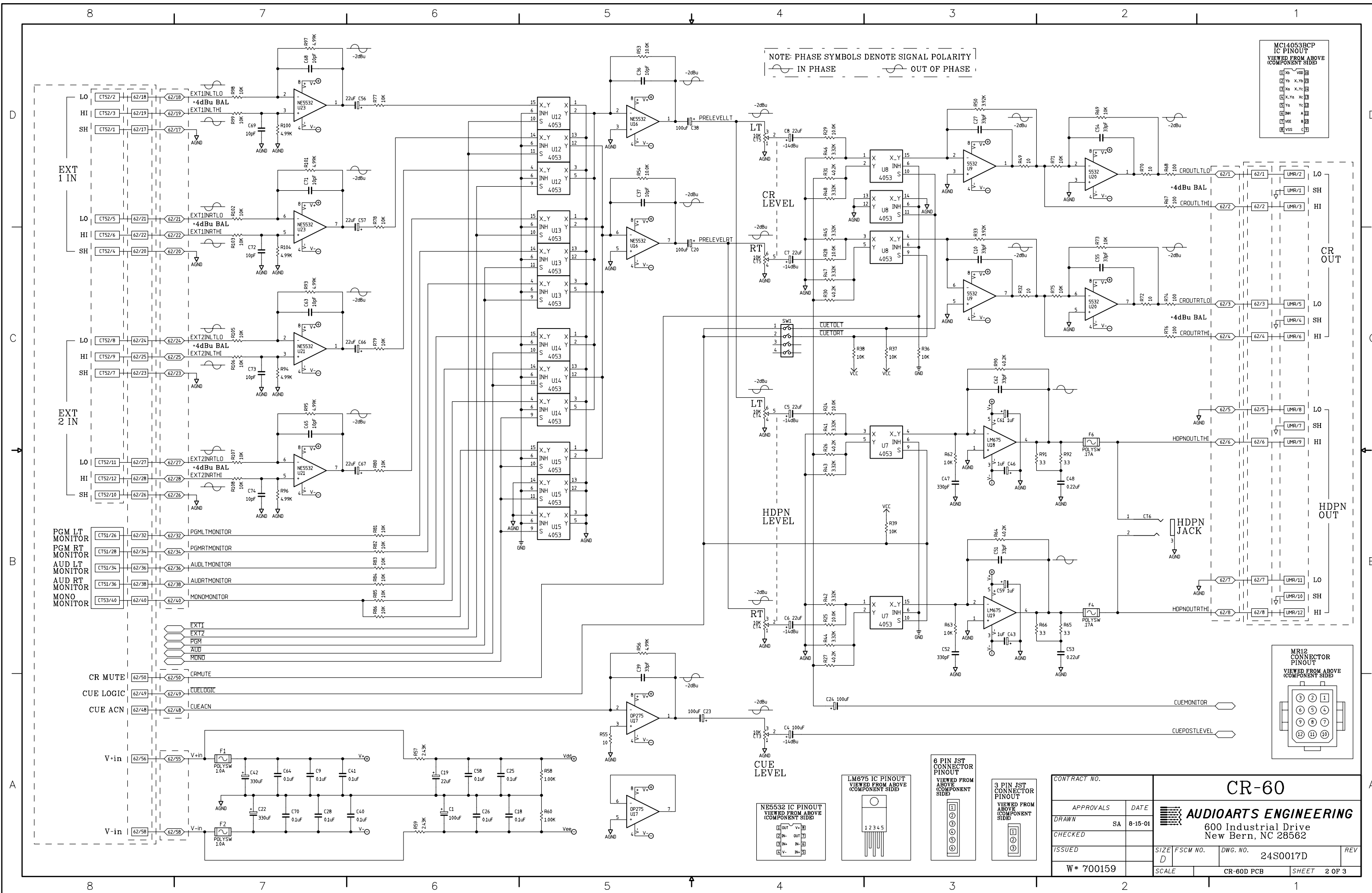

CR-60 Control Room Module Schematic - Sheet 2 of 3 Page 6-12

CONTRACT NO.		APPROVALS		DATE	<b>AUDIOARTS ENGINEERING</b> 600 Industrial Drive New Bern, NC 28562
DRAWN		SA	8-15-01		
CHECKED		ISSUED		SIZE	FSCM NO.
W # 700159		SCALE		D	DWG. NO. 24S0017D
		CR-60D PCB		REV	
		SHEET		2 OF 3	

## EDGE CONNECTOR BUSS CHART

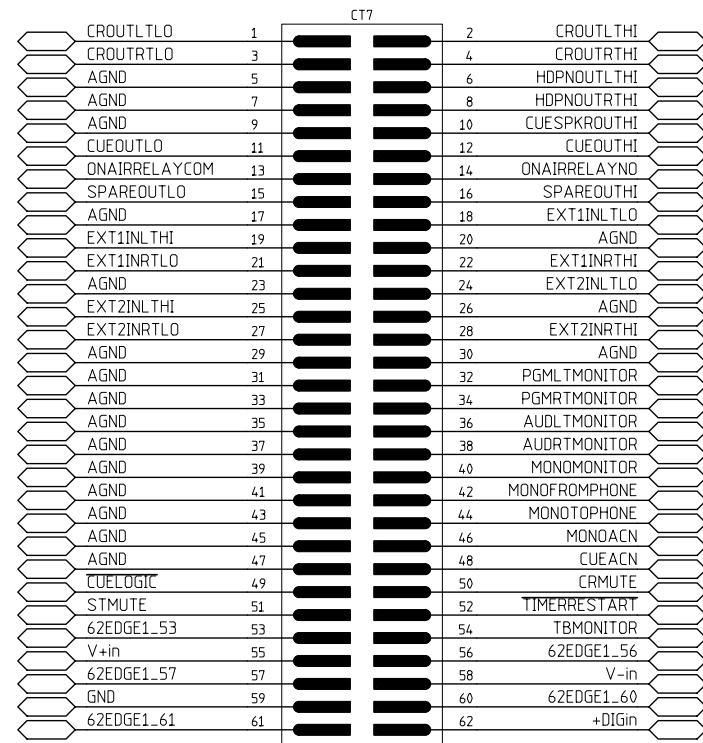

CONTRACT NO.		<b>CR-60</b>			
APPROVALS	DATE	<b>AUDIOARTS ENGINEERING</b> 600 Industrial Drive New Bern, NC 28562			
DRAWN SA	8-15-01				
CHECKED		SIZE	FSCM NO.	DWG. NO.	REV
ISSUED		B		24S0018D	-
W* 700159		SCALE	CR-60D PCB	SHEET	3 OF 3

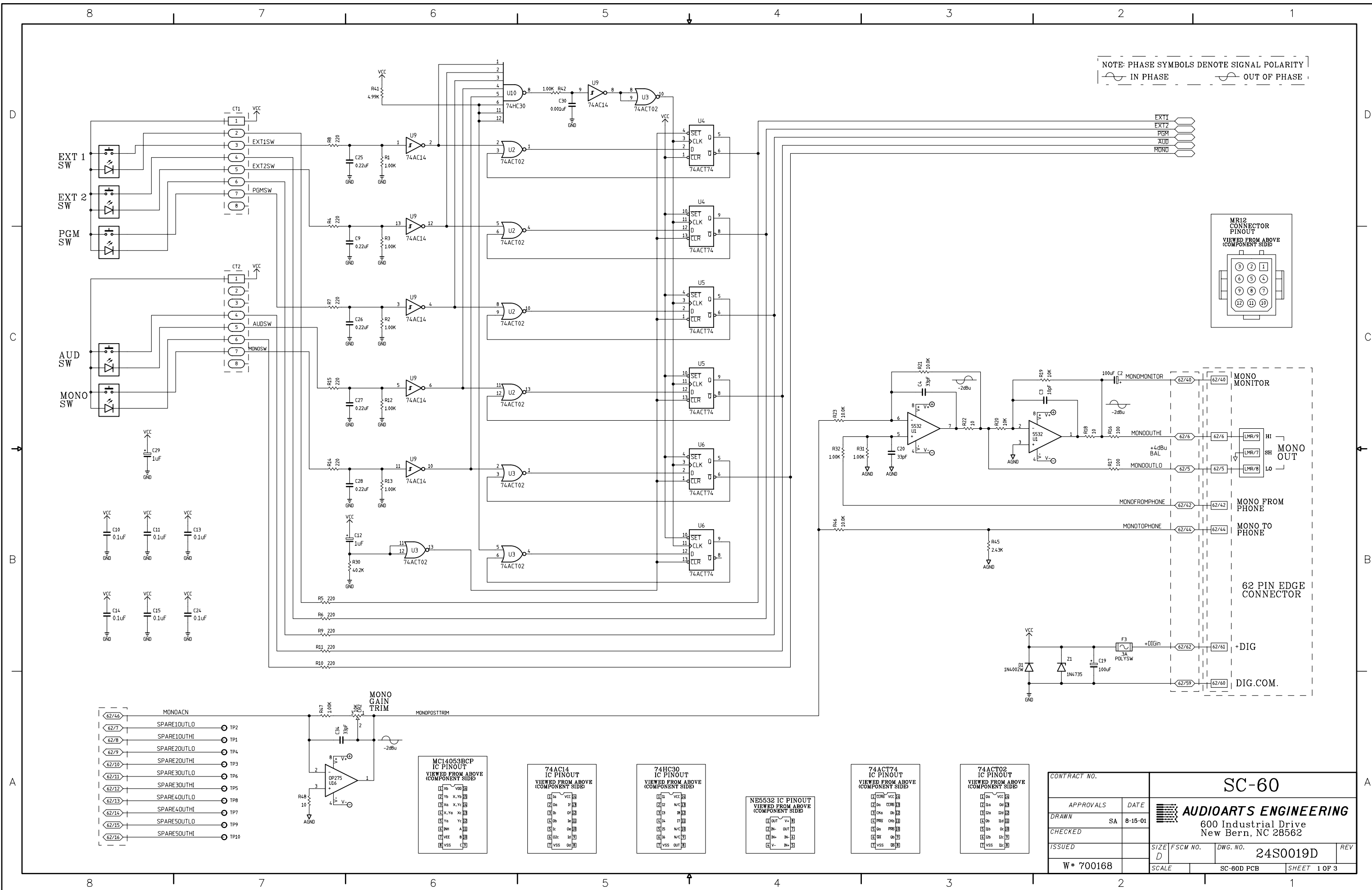

NOTE: PHASE SYMBOLS DENOTE SIGNAL POLARITY  
 IN PHASE      OUT OF PHASE

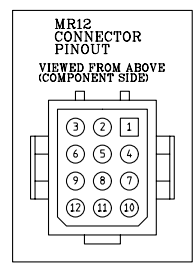

MONO MONITOR

MONO OUTPUT

MONO FROM PHONE

MONO TO PHONE

62 PIN EDGE CONNECTOR

+DIG

DIG.COM.

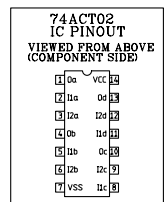
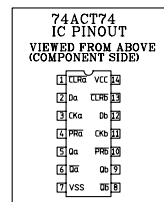
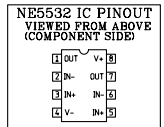
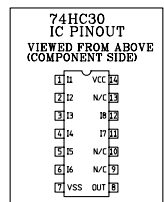
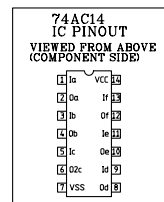
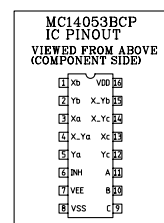

CONTRACT NO.		<b>SC-60</b>			
APPROVALS	DATE	<b>AUDIOARTS ENGINEERING</b> 600 Industrial Drive New Bern, NC 28562			
DRAWN	SA 8-15-01				
CHECKED					
ISSUED		SIZE	FSCM NO.	DWG. NO.	REV
W# 700168		D		24S0019D	
		SCALE	SC-60D PCB	SHEET 1 OF 3	



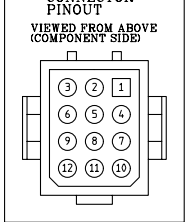
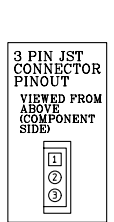
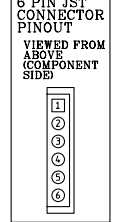
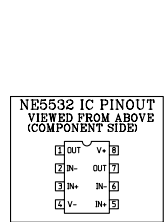
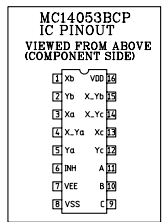
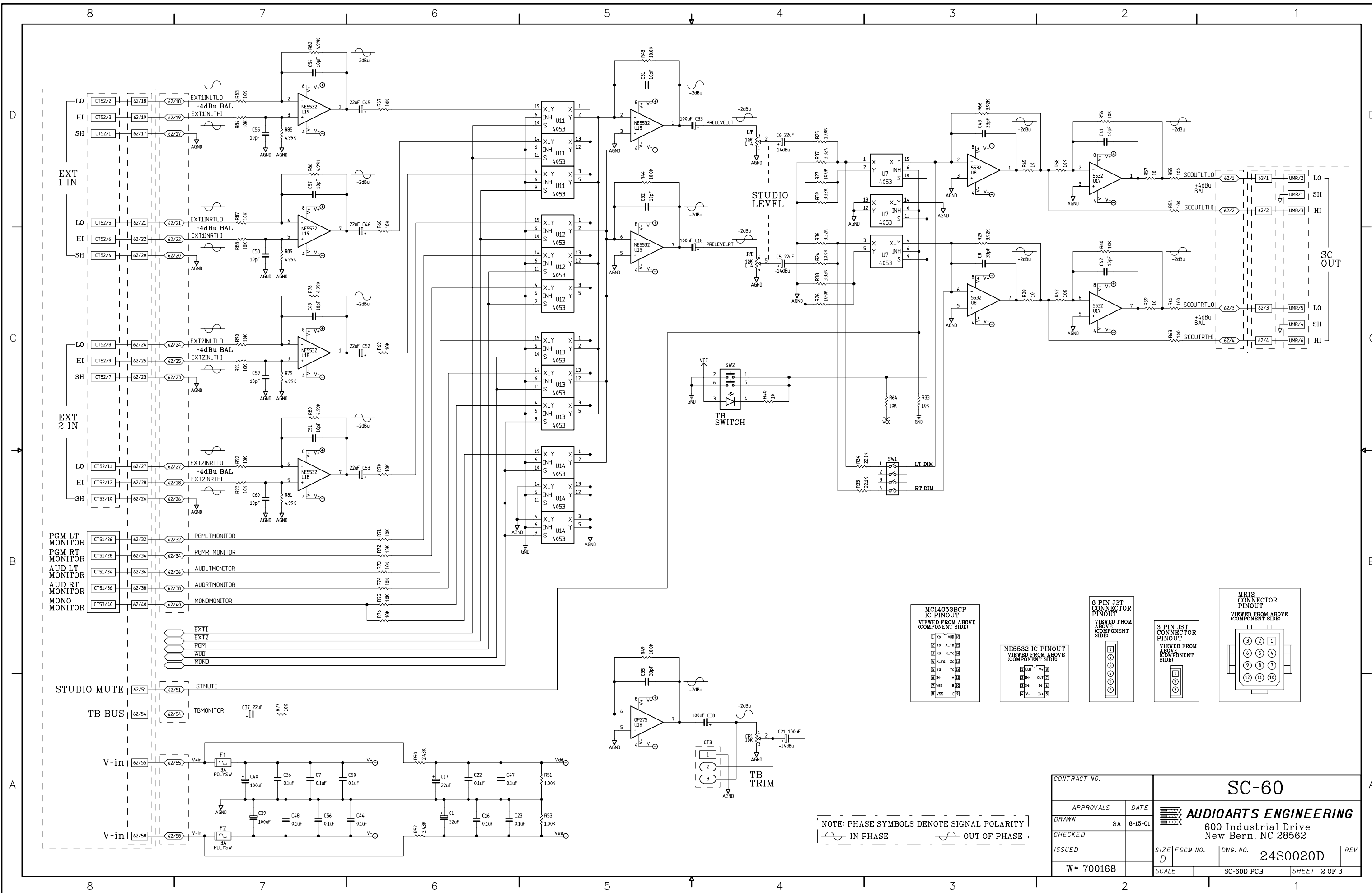

NOTE: PHASE SYMBOLS DENOTE SIGNAL POLARITY  
 IN PHASE  
 OUT OF PHASE

CONTRACT NO.		SC-60	
APPROVALS	DATE	AUDIOARTS ENGINEERING	
DRAWN SA	8-15-01	600 Industrial Drive	
CHECKED		New Bern, NC 28562	
ISSUED		SIZE FSCM NO.	DWG. NO. 24S0020D
W# 700168		SCALE	SC-60D PCB SHEET 2 OF 3

## EDGE CONNECTOR BUSS CHART

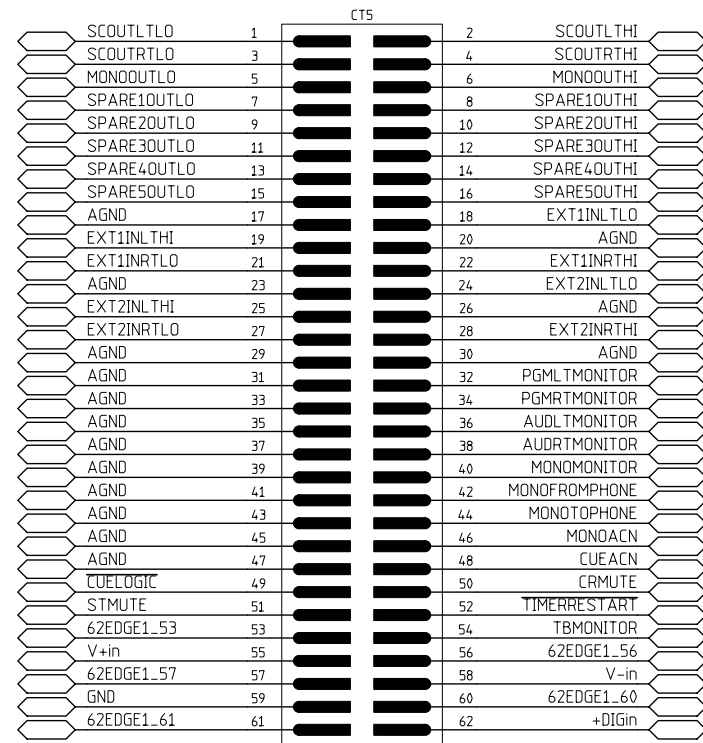

CONTRACT NO.		<b>SC-60</b>			
APPROVALS	DATE	<b>AUDIOARTS ENGINEERING</b> 600 Industrial Drive New Bern, NC 28562			
DRAWN SA	8-15-01				
CHECKED		SIZE	FSCM NO.	DWG. NO.	REV
ISSUED		B		24S0021D	-
W* 700168		SCALE	SC-60D PCB	SHEET	3 OF 3

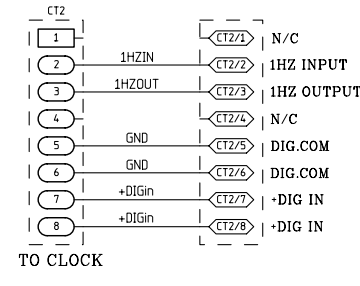
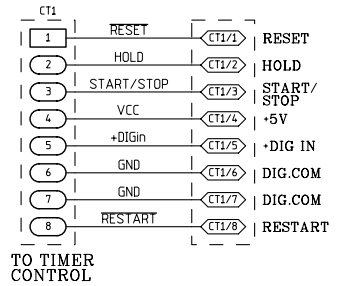
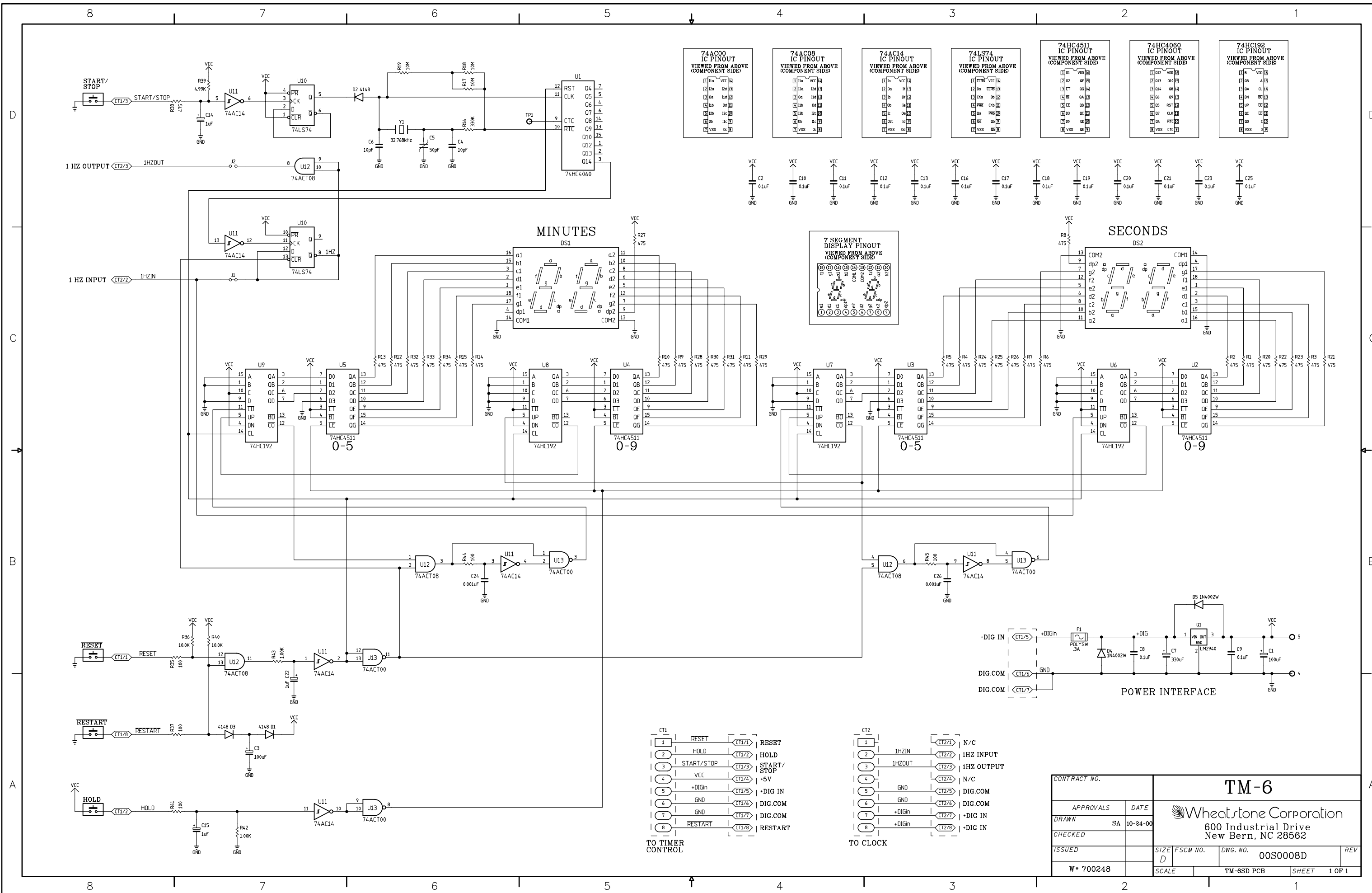

CONTRACT NO.		<b>TM-6</b>				
APPROVALS	DATE					
DRAWN	SA 10-24-00	Wheatstone Corporation 600 Industrial Drive New Bern, NC 28562				
CHECKED						
ISSUED		SIZE	FSCM NO.	DWG. NO.	00S0008D	REV
W * 700248		D		TM-6SD PCB		
		SCALE		SHEET	1 OF 1	

Timer Schematic - Sheet 1 of 1

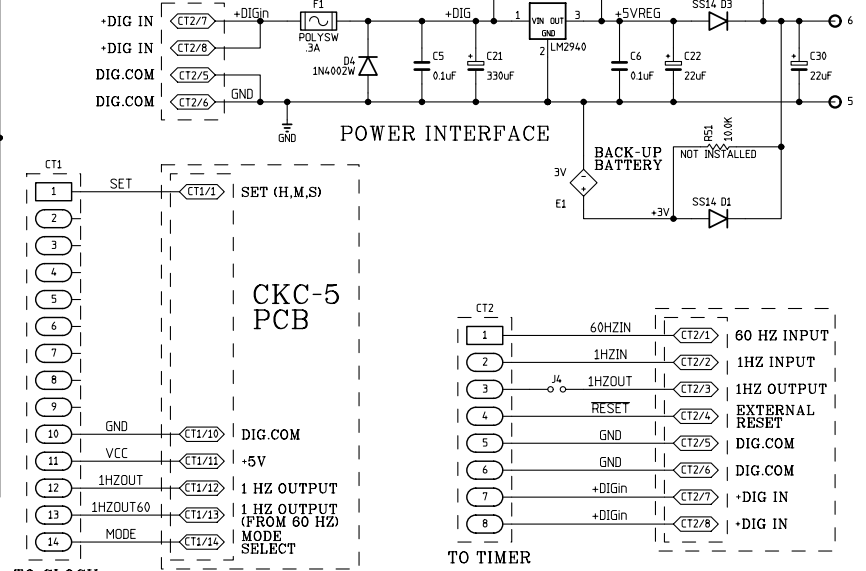
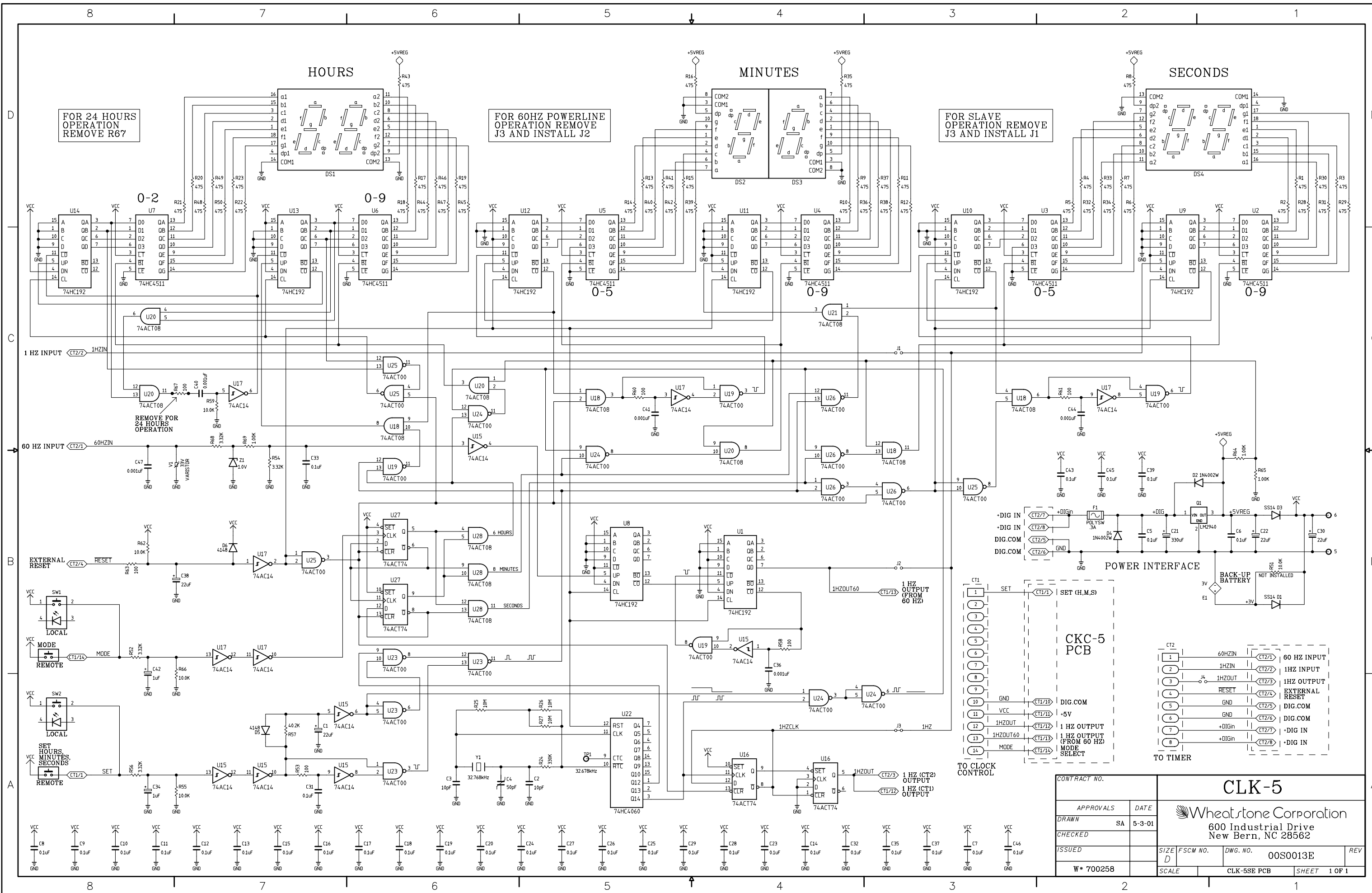

CONTRACT NO.		<b>CLK-5</b>			
APPROVALS	DATE				
DRAWN	SA 5-3-01	Wheatstone Corporation 600 Industrial Drive New Bern, NC 28562			
CHECKED					
ISSUED		SIZE D	FSCM NO.	DWG. NO. 00S0013E	REV
W* 700258		SCALE	CLK-5SE PCB	SHEET 1 OF 1	

Clock Schematic - Sheet 1 of 1

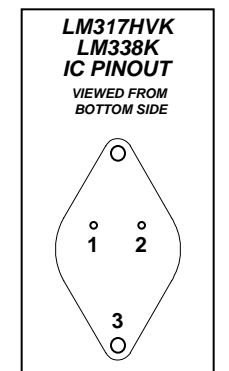
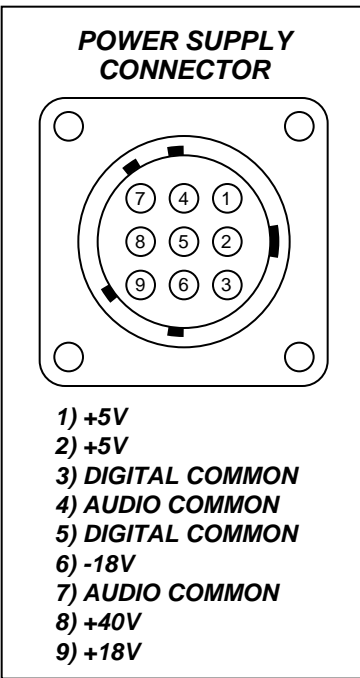
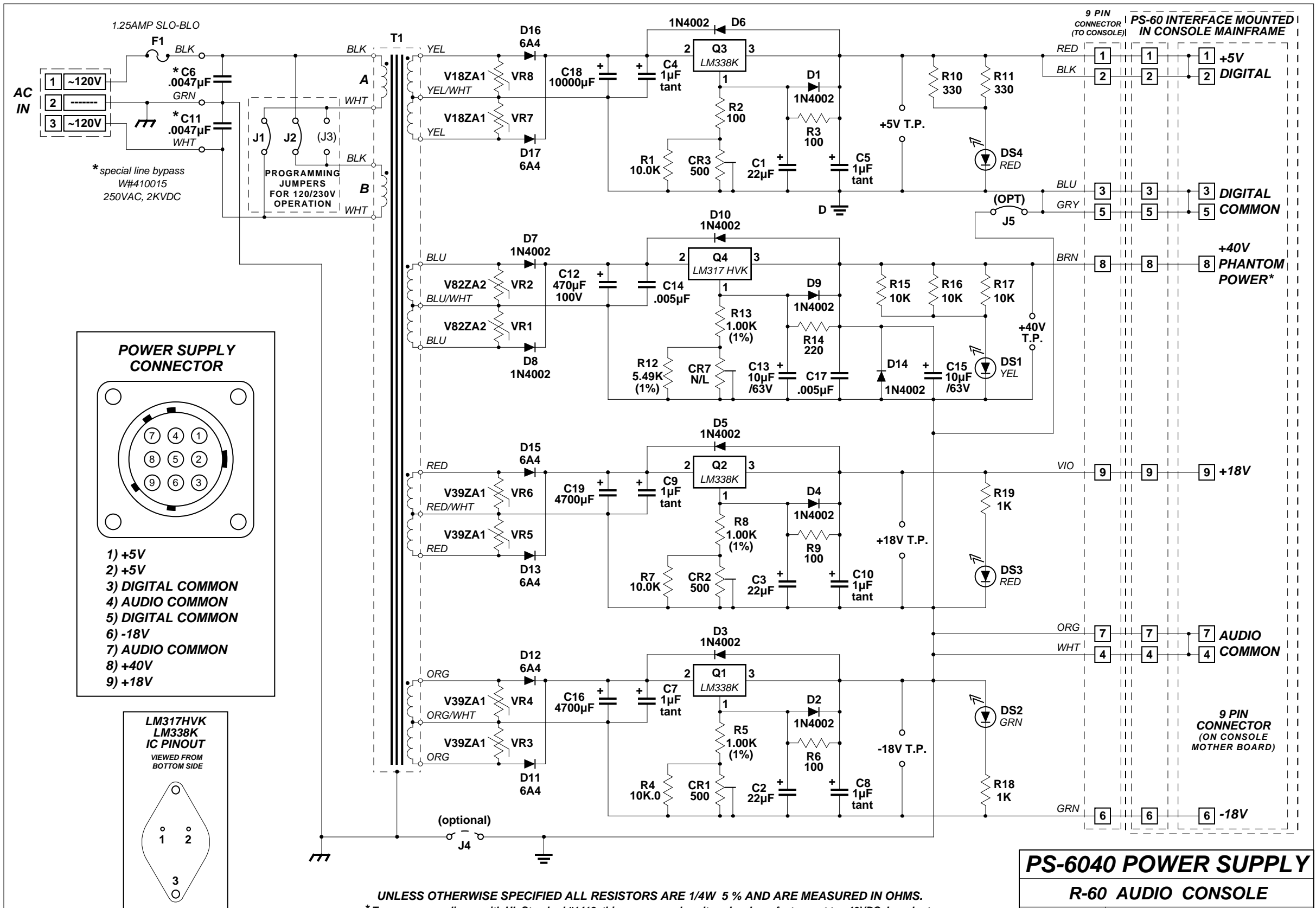

UNLESS OTHERWISE SPECIFIED ALL RESISTORS ARE 1/4W 5% AND ARE MEASURED IN OHMS.  
 \* To ensure compliance with UL Standard #1419, this power supply voltage has been factory set to +40VDC. In order to maintain protection under these standards, do not modify this voltage setting to be greater than +40VDC.

**PS-6040 Power Supply Schematic Drawing**

R60 / May 2000

PS-6040 POWER SUPPLY		
R-60 AUDIO CONSOLE		
07-25-96	Wheatstone Corporation	
S.A.	600 Industrial Drive	
rev 5-19-00/KP	New Bern, NC. 28562	
W# 700205	PS-6040A PCB	24S0001C

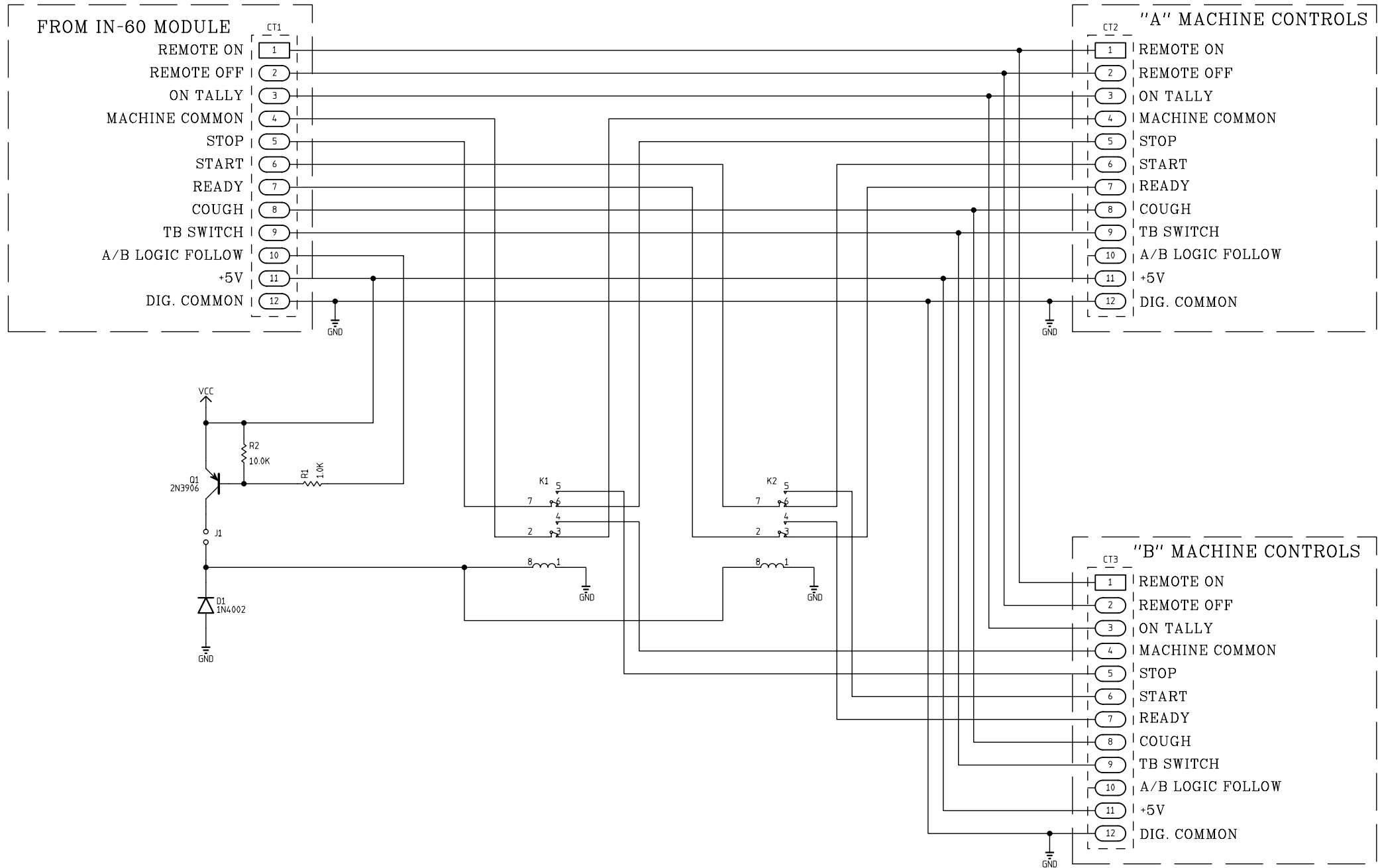

CONTRACT NO.		<b>LF-60</b>			
APPROVALS	DATE	<b>AUDIOARTS ENGINEERING</b> 600 Industrial Drive New Bern, NC 28562			
DRAWN SA	10-6-99				
CHECKED		SIZE	FSCM NO.	DWG. NO.	REV
ISSUED		C		24S0033A	-
W* 700198		SCALE	LF-60A PCB	SHEET 1 OF 1	

LF-60 Logic Follow Schematic - Sheet 1 of 1

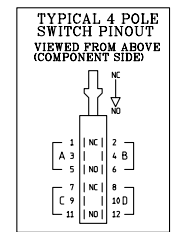
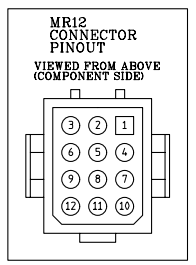
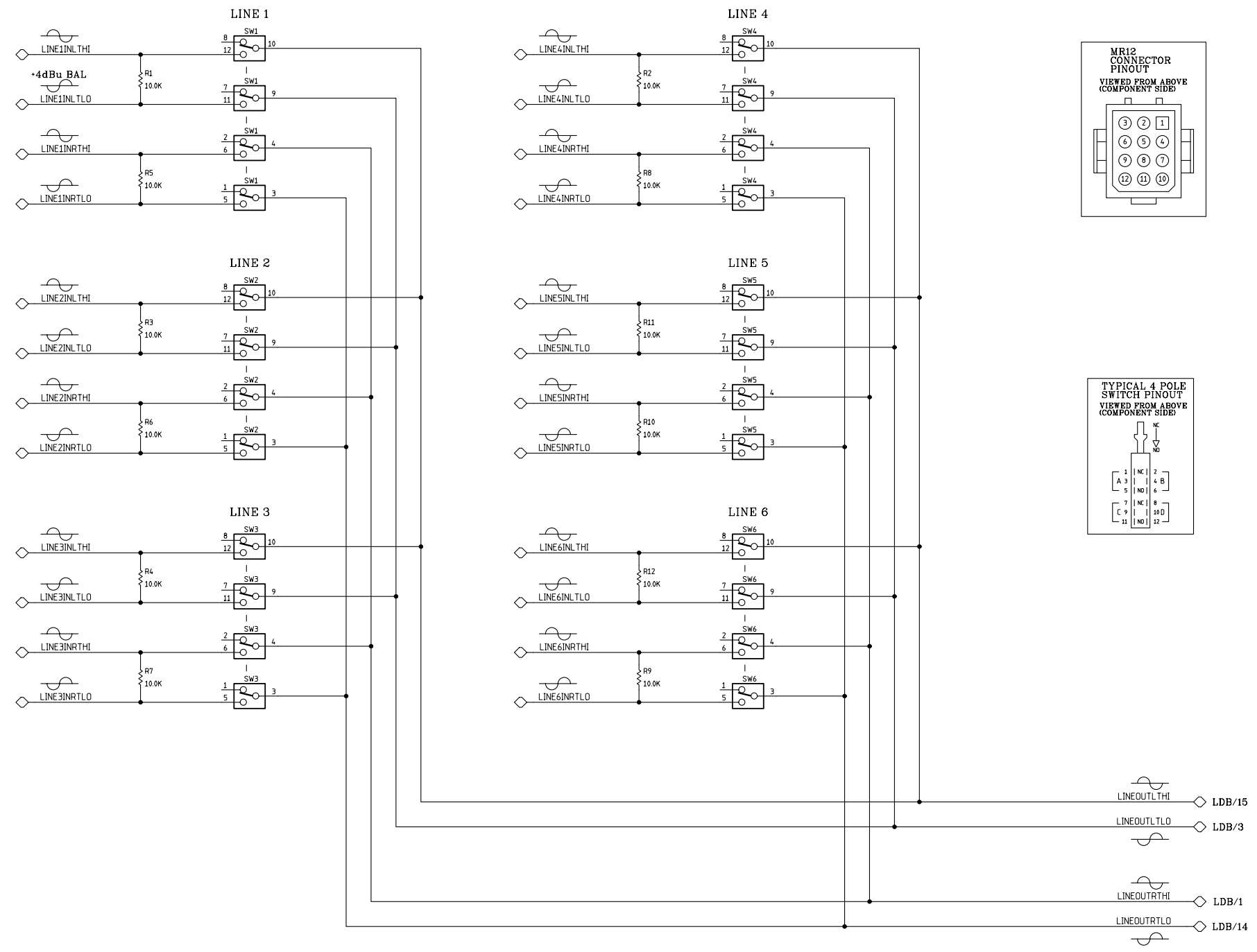
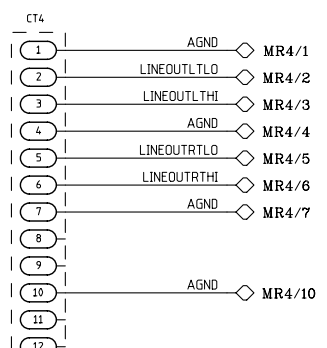
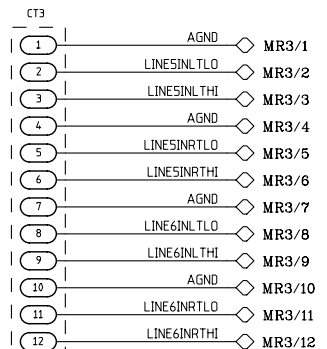
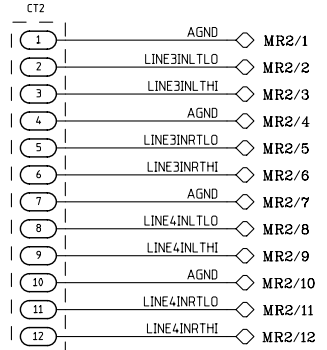
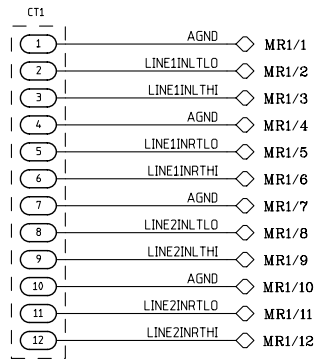

CONTRACT NO.		<b>LS-60</b>			
APPROVALS	DATE	<b>AUDIOARTS ENGINEERING</b> 600 Industrial Drive New Bern, NC 28562			
DRAWN	SA 3-23-01				
CHECKED					
ISSUED		SIZE	FSCM NO.	DWG. NO.	REV
W * 700053		D		24S0025	
		SCALE	LS-60B PCB		SHEET 1 OF 1

---

# Load Sheets

## Chapter Contents

- R-60 EXT Mother board ..... 7-2
- R-60 mother board ..... 7-3
- IN-60 input module ..... 7-4
- INS-60 switch board ..... 7-5
- DMP-60 dual mic preamp ..... 7-6
- OM-60 board ..... 7-7
- TCS-60 timer control switch card ..... 7-8
- CR-60 control room module ..... 7-9
- SC-60 studio control module ..... 7-10
- MS-60 monitor switch card ..... 7-11
- SP-60 Simple Phone™ input ..... 7-12
- TR-60 board ..... 7-13
- TM-6 timer card ..... 7-14
- CLK-5 clock card ..... 7-15
- PS-6040 power supply ..... 7-16
- LF-60 logic follow ..... 7-17
- LS-60 line select ..... 7-18



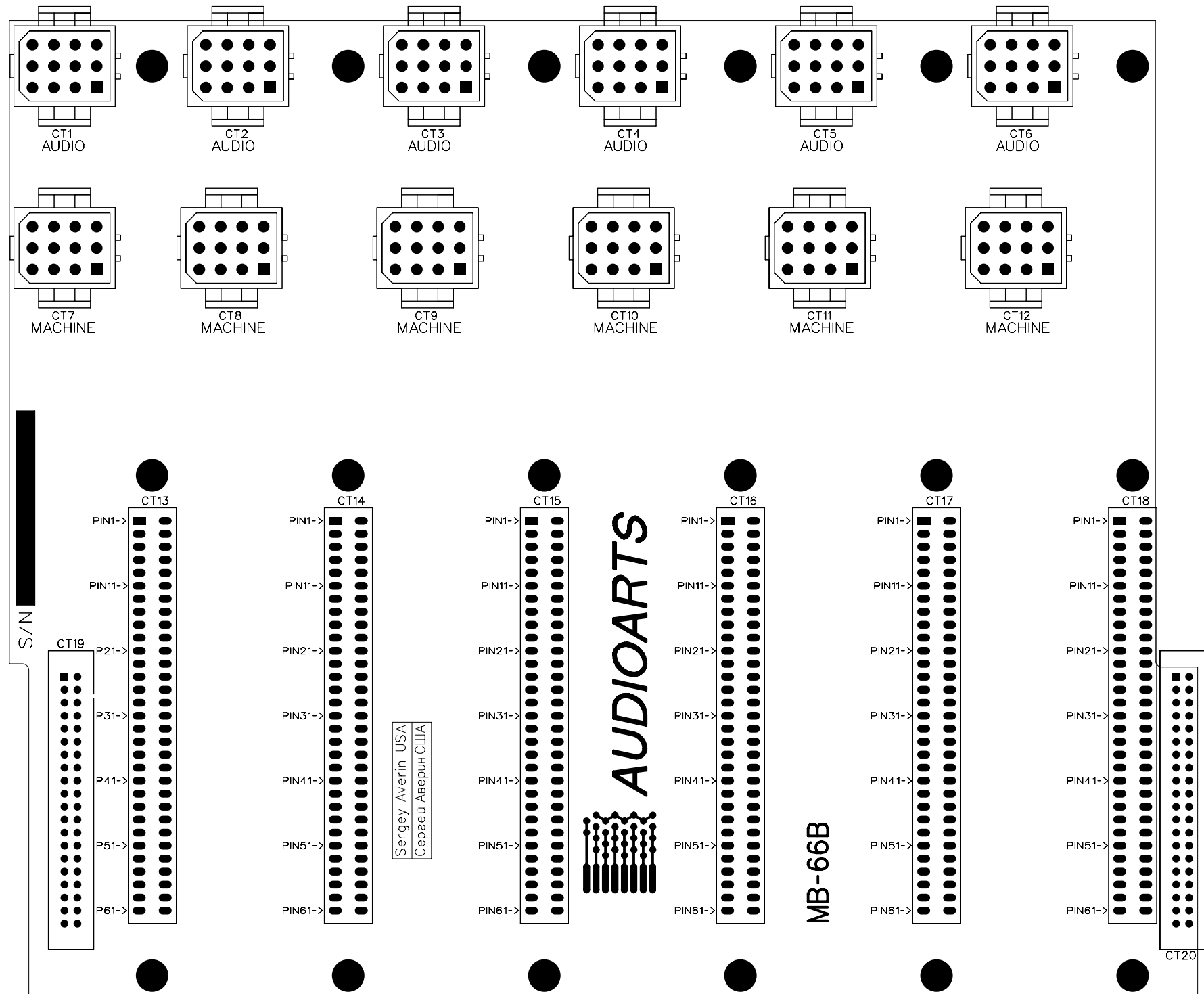

S/N

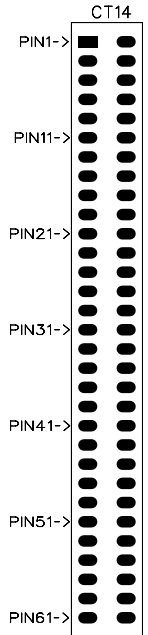
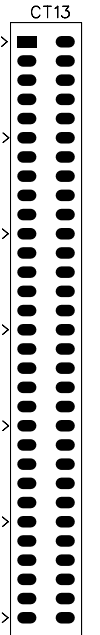
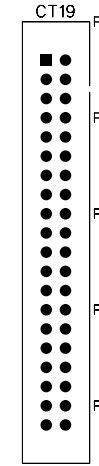

Sergey Averin USA  
Сергей Аверин США

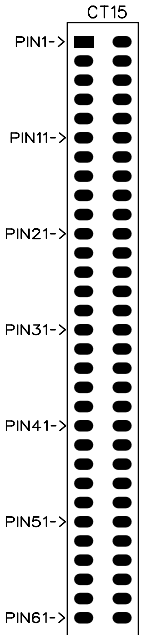

**AUDIOARTS**

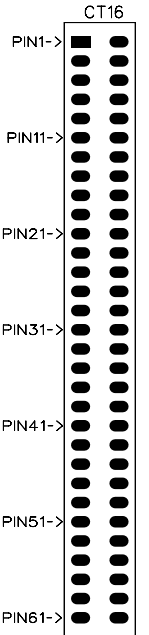

MB-66B

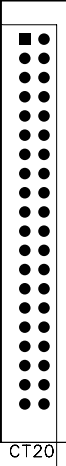
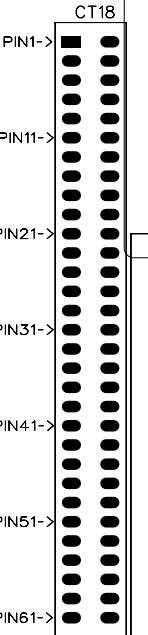
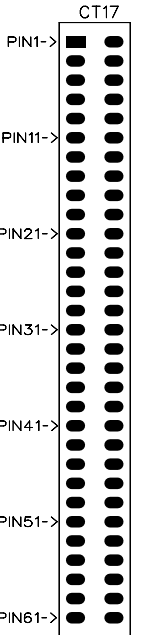

CT20

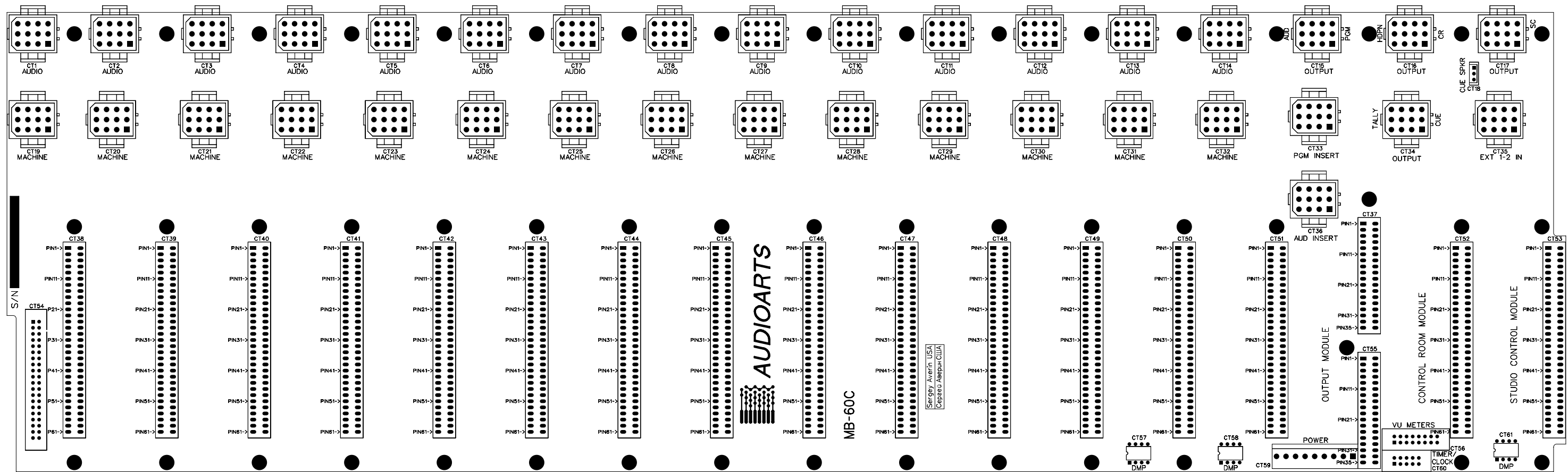

**AUDIOARTS**

MB-60C

Sergioy Avetis USA  
Cepreu /Ampar/CIJA

S/N

CT54

P1-  
P2-  
P3-  
P4-  
P5-  
P6-

CT38

PIN1-  
PIN11-  
PIN21-  
PIN31-  
PIN41-  
PIN51-  
PIN61-

CT39

PIN1-  
PIN11-  
PIN21-  
PIN31-  
PIN41-  
PIN51-  
PIN61-

CT40

PIN1-  
PIN11-  
PIN21-  
PIN31-  
PIN41-  
PIN51-  
PIN61-

CT41

PIN1-  
PIN11-  
PIN21-  
PIN31-  
PIN41-  
PIN51-  
PIN61-

CT42

PIN1-  
PIN11-  
PIN21-  
PIN31-  
PIN41-  
PIN51-  
PIN61-

CT43

PIN1-  
PIN11-  
PIN21-  
PIN31-  
PIN41-  
PIN51-  
PIN61-

CT44

PIN1-  
PIN11-  
PIN21-  
PIN31-  
PIN41-  
PIN51-  
PIN61-

CT45

PIN1-  
PIN11-  
PIN21-  
PIN31-  
PIN41-  
PIN51-  
PIN61-

CT46

PIN1-  
PIN11-  
PIN21-  
PIN31-  
PIN41-  
PIN51-  
PIN61-

CT47

PIN1-  
PIN11-  
PIN21-  
PIN31-  
PIN41-  
PIN51-  
PIN61-

CT48

PIN1-  
PIN11-  
PIN21-  
PIN31-  
PIN41-  
PIN51-  
PIN61-

CT49

PIN1-  
PIN11-  
PIN21-  
PIN31-  
PIN41-  
PIN51-  
PIN61-

CT50

PIN1-  
PIN11-  
PIN21-  
PIN31-  
PIN41-  
PIN51-  
PIN61-

CT51

PIN1-  
PIN11-  
PIN21-  
PIN31-  
PIN41-  
PIN51-  
PIN61-

CT52

PIN1-  
PIN11-  
PIN21-  
PIN31-  
PIN41-  
PIN51-  
PIN61-

CT53

PIN1-  
PIN11-  
PIN21-  
PIN31-  
PIN41-  
PIN51-  
PIN61-

CT54

PIN1-  
PIN2-  
PIN3-  
PIN4-  
PIN5-

CT55

PIN1-  
PIN2-  
PIN3-  
PIN4-  
PIN5-

CT56

PIN1-  
PIN2-  
PIN3-  
PIN4-  
PIN5-

CT61

PIN1-  
PIN2-  
PIN3-  
PIN4-  
PIN5-

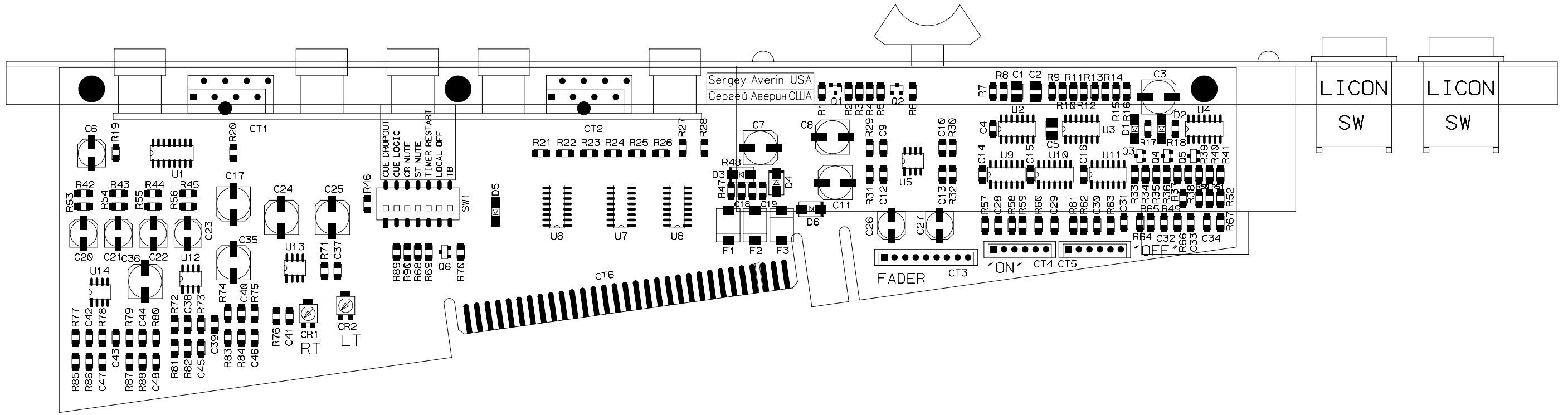
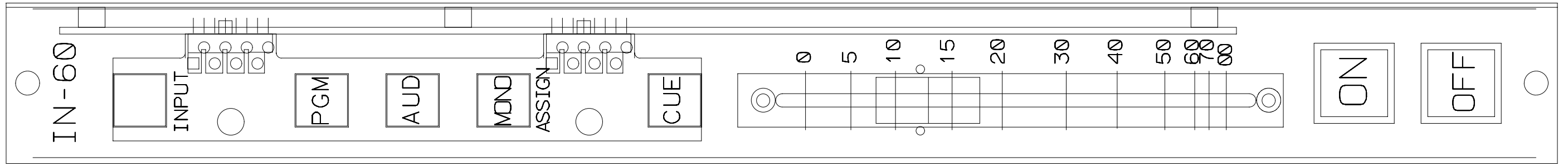

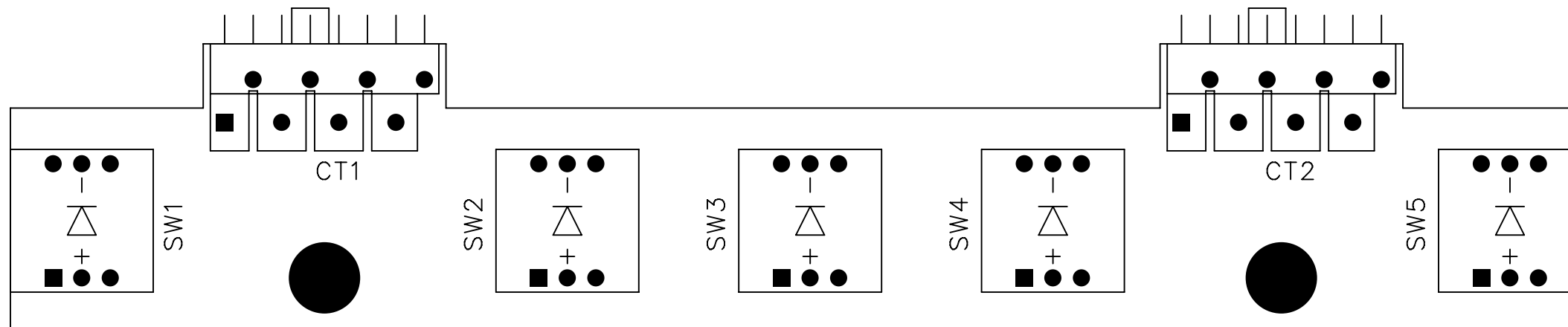

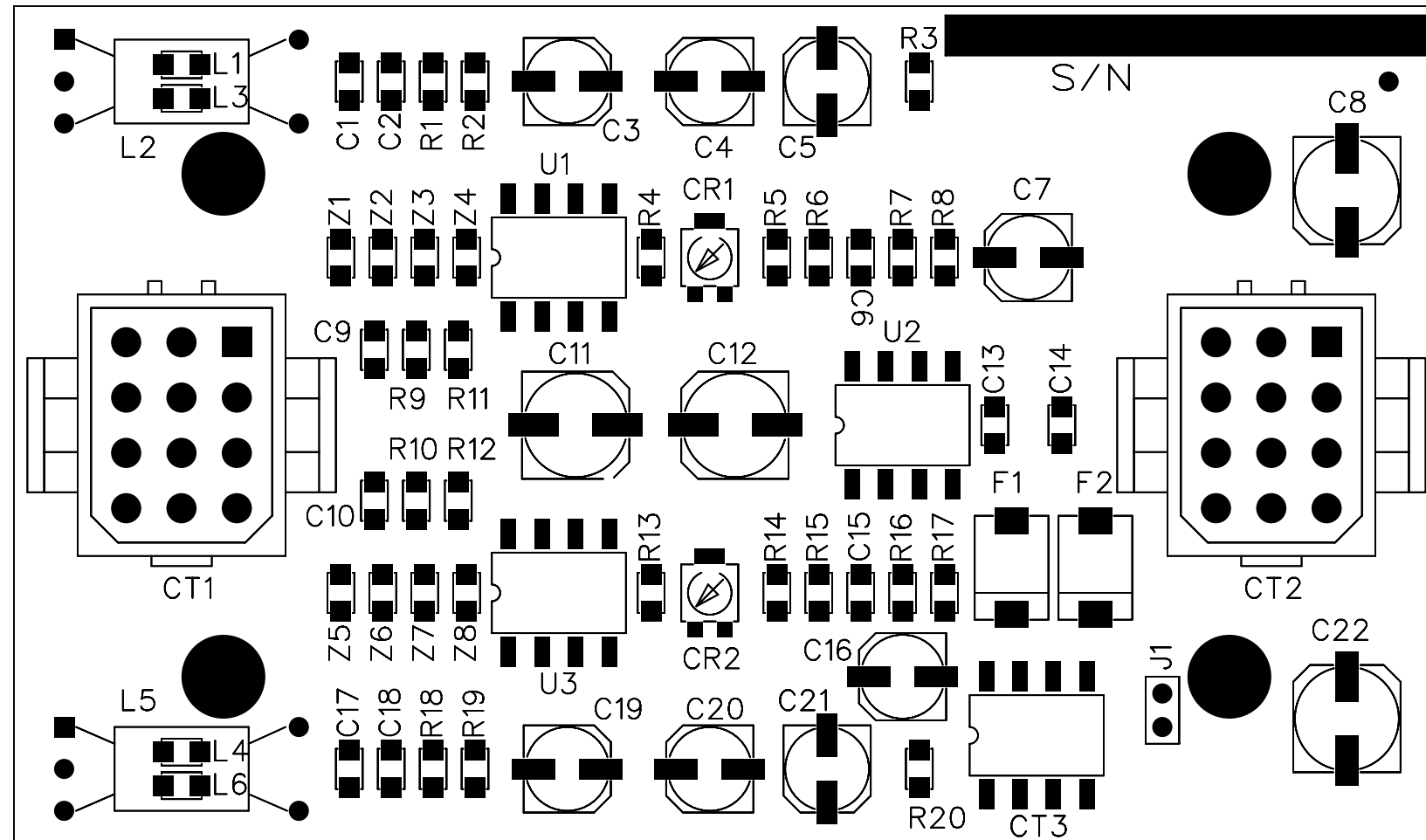

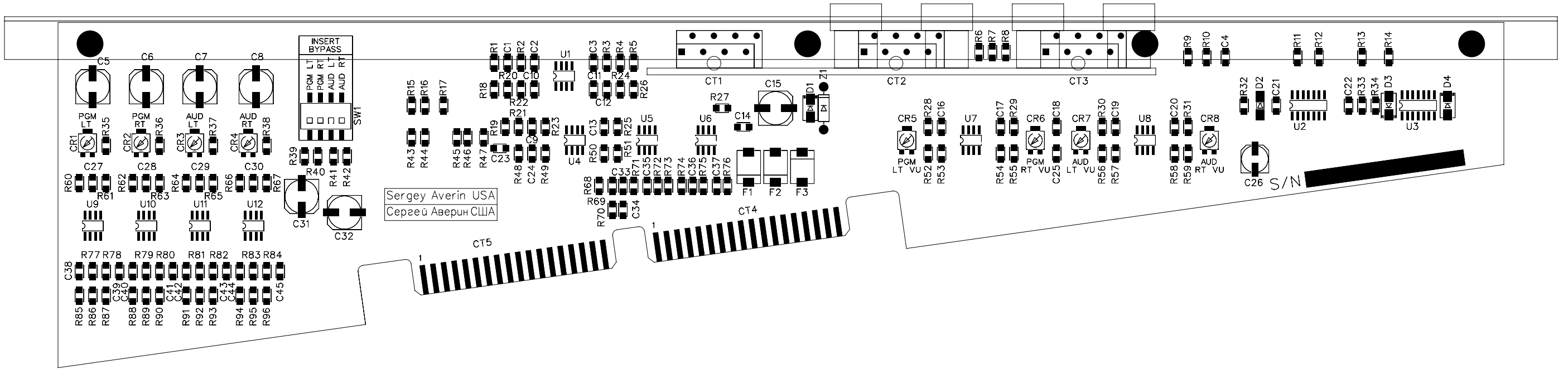
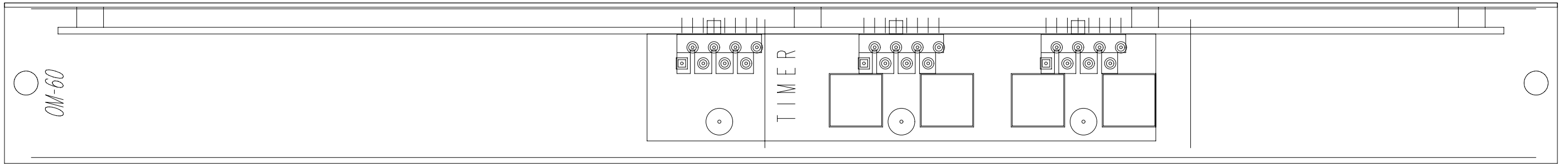

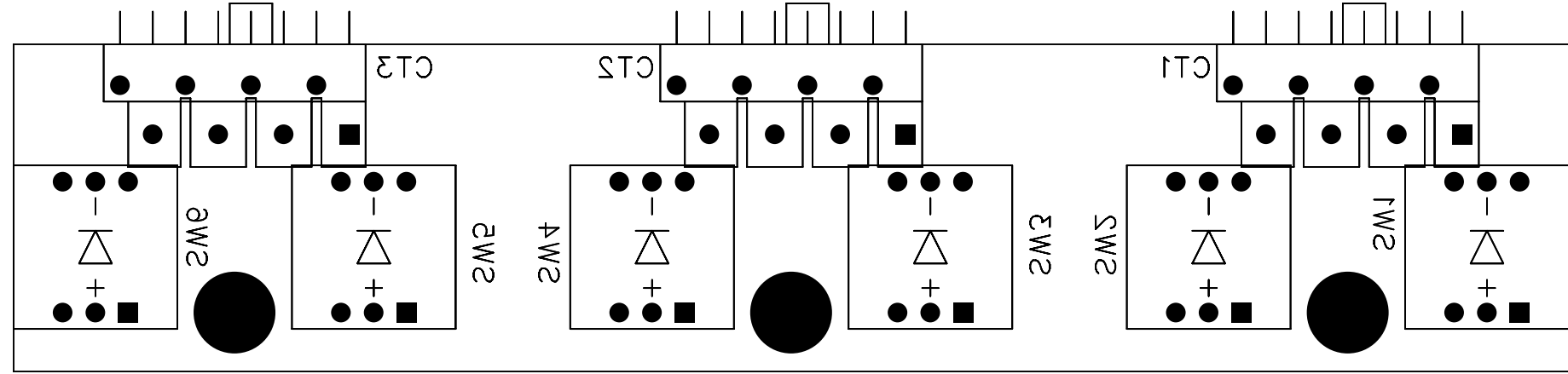

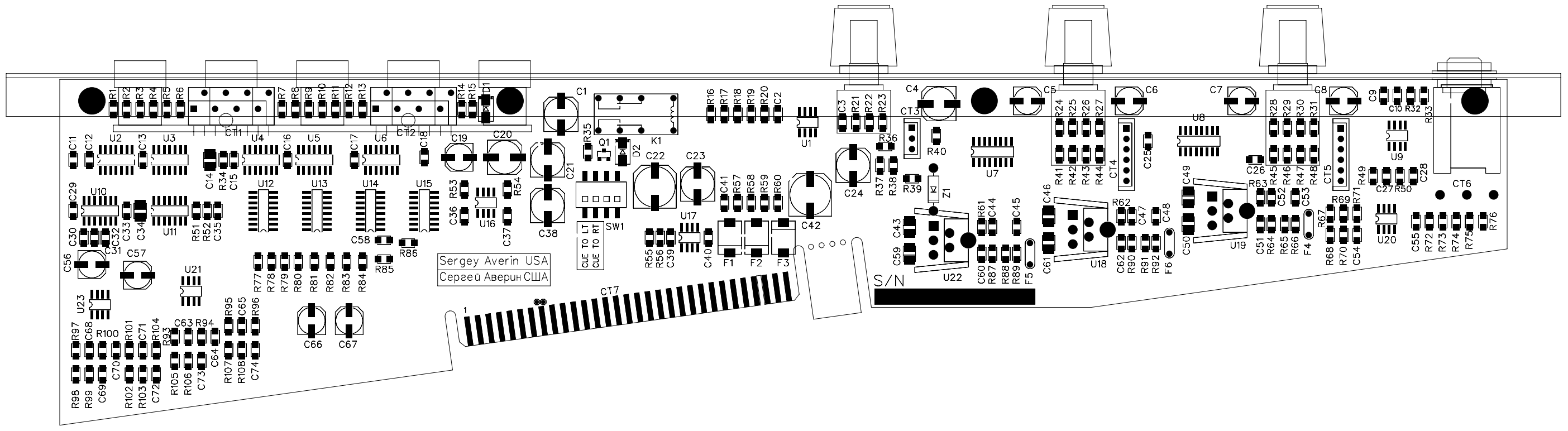
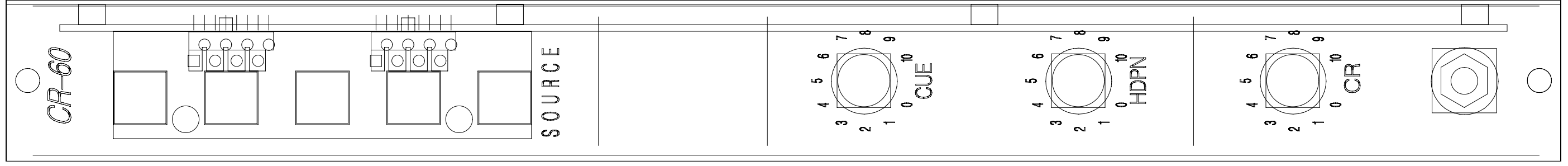



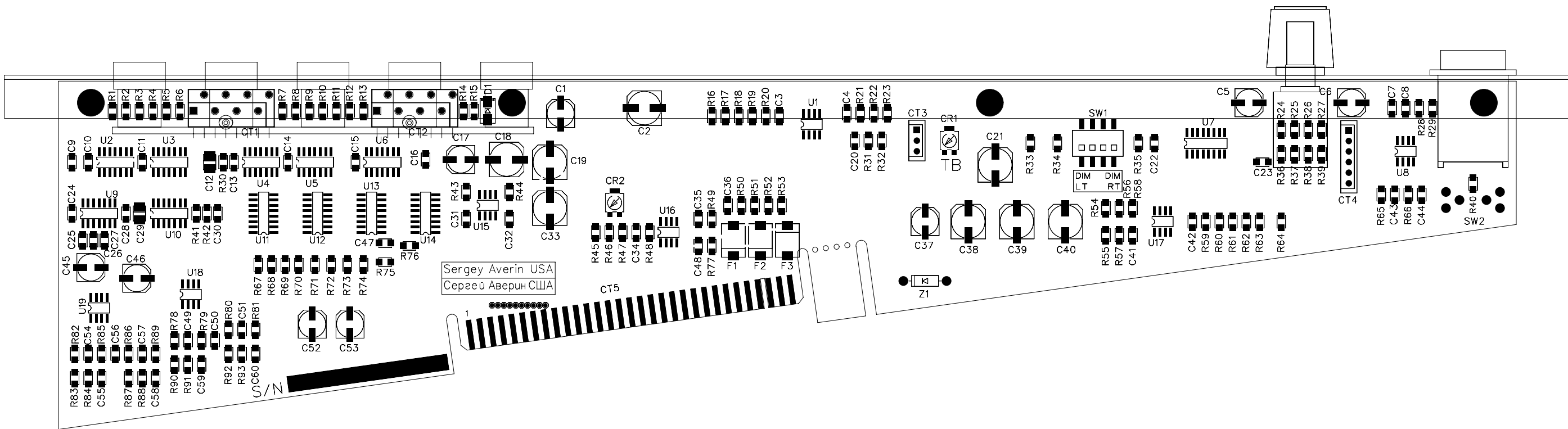
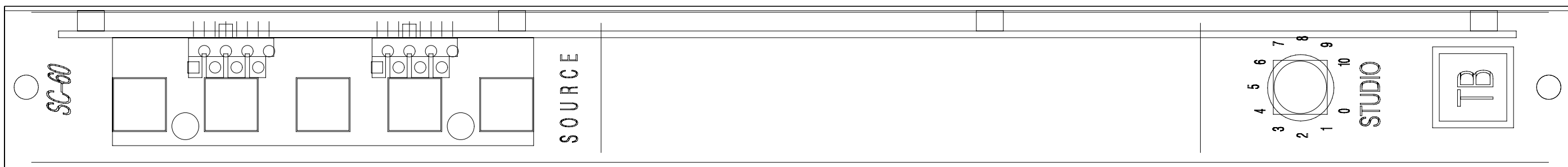

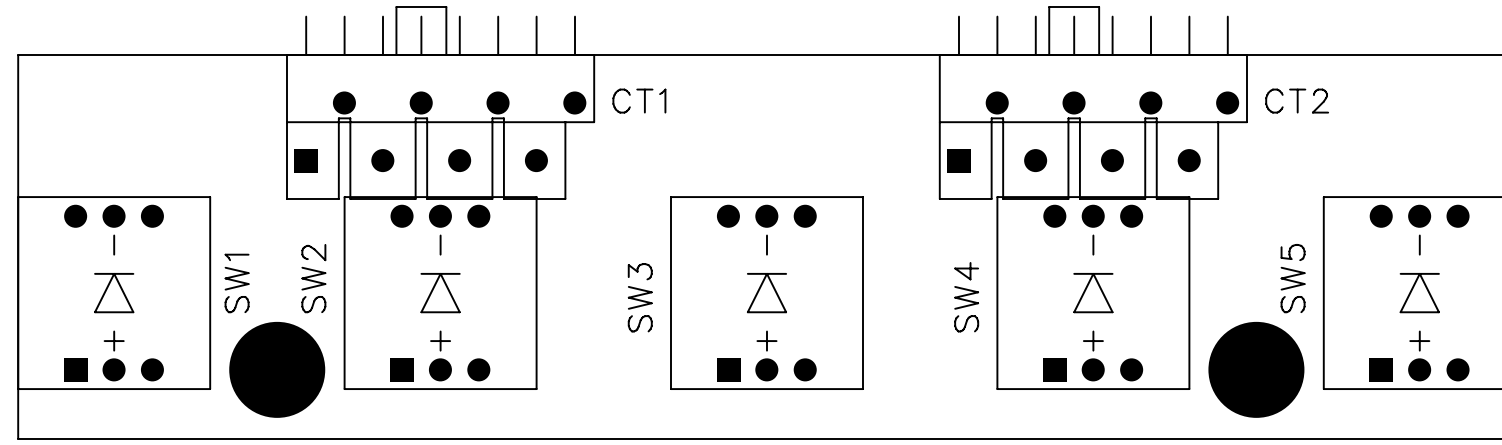

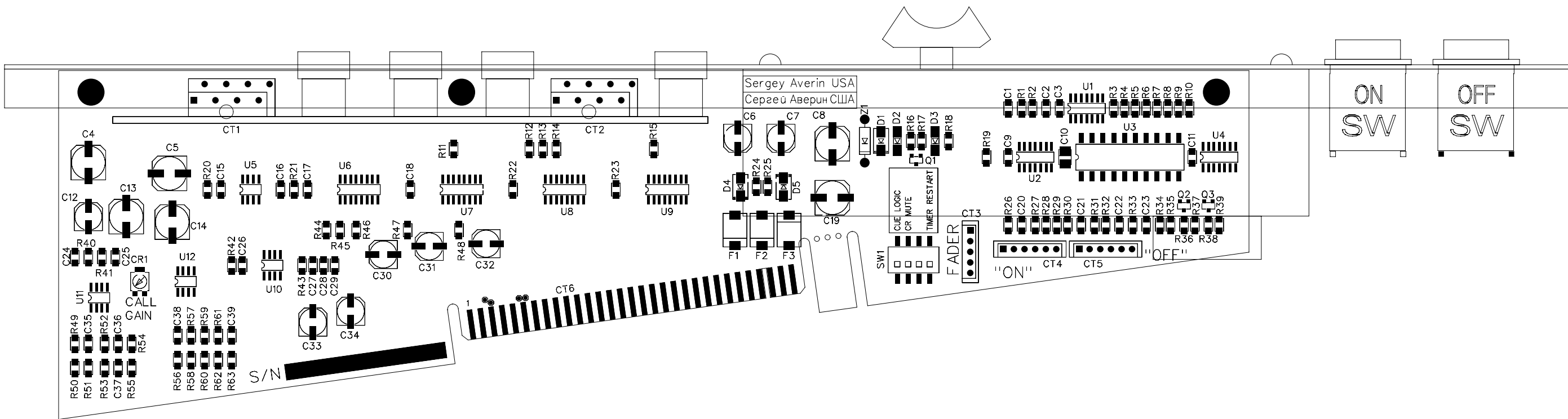
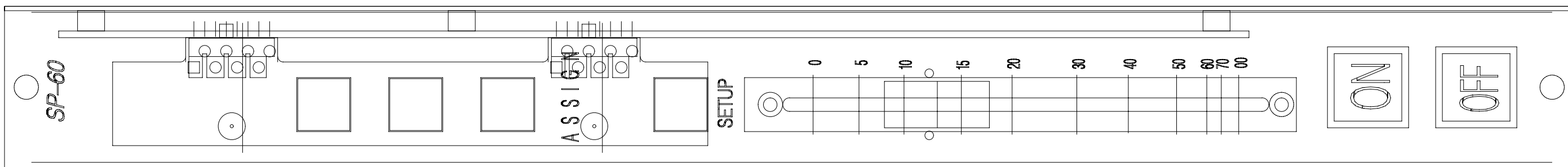

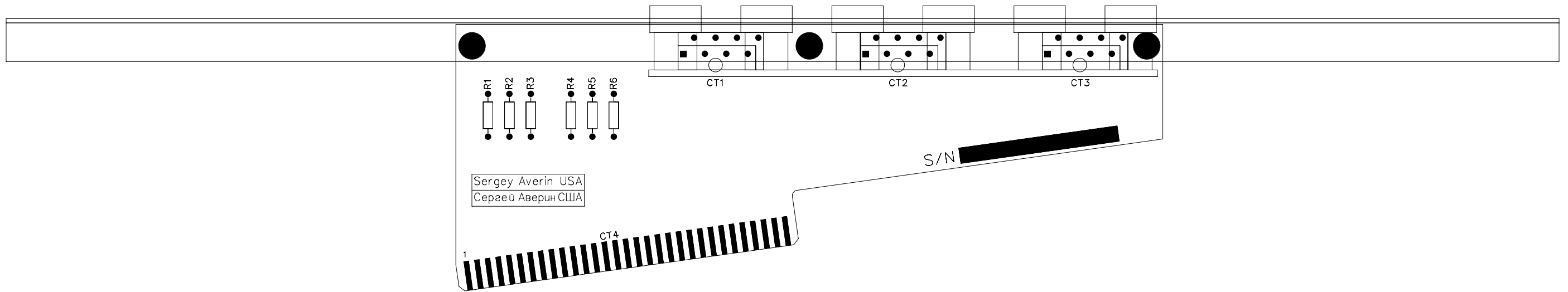
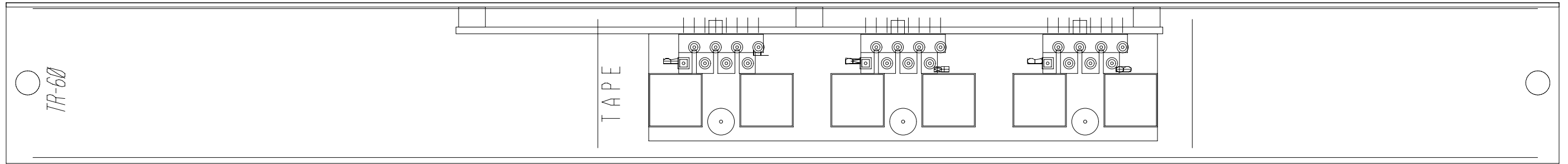

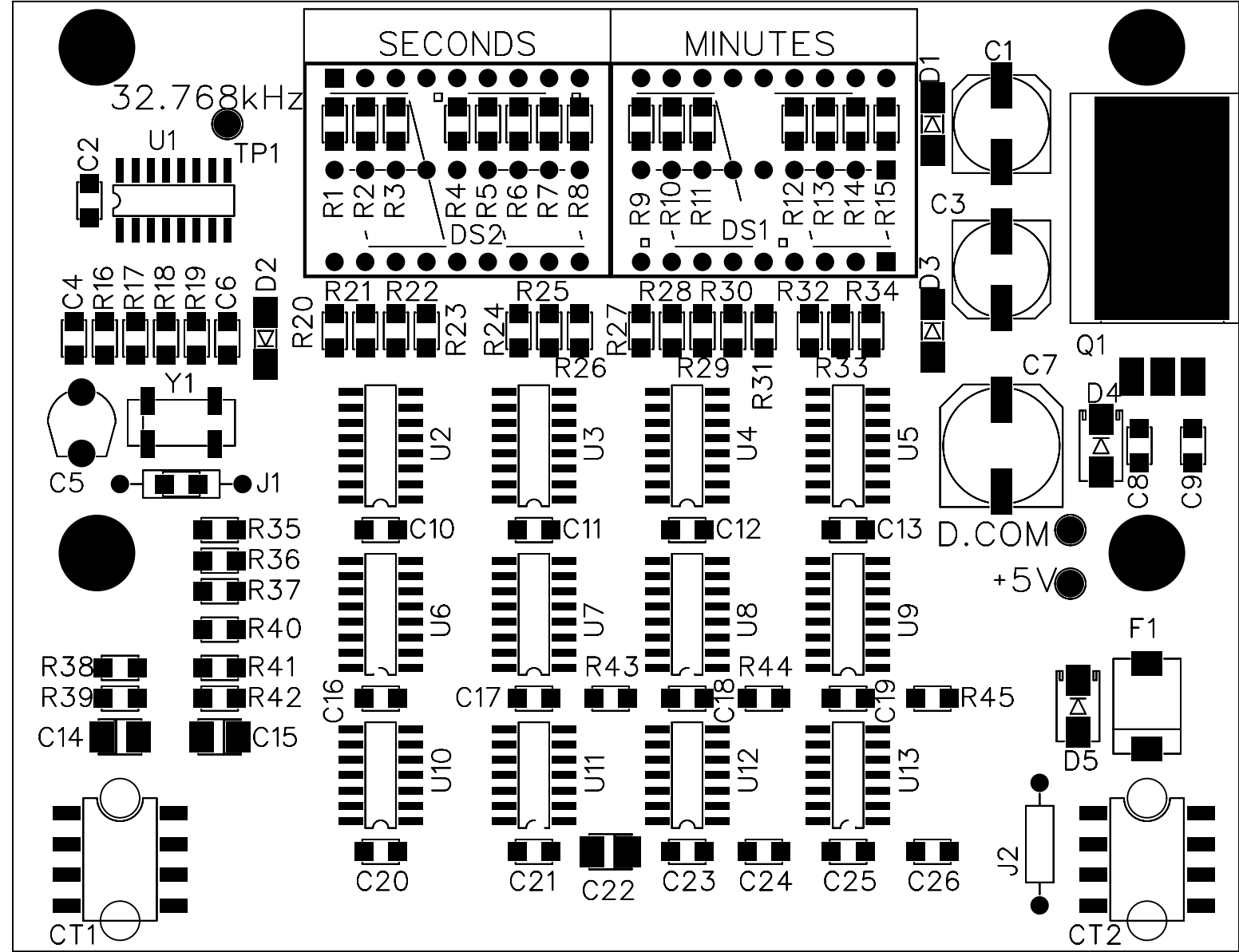

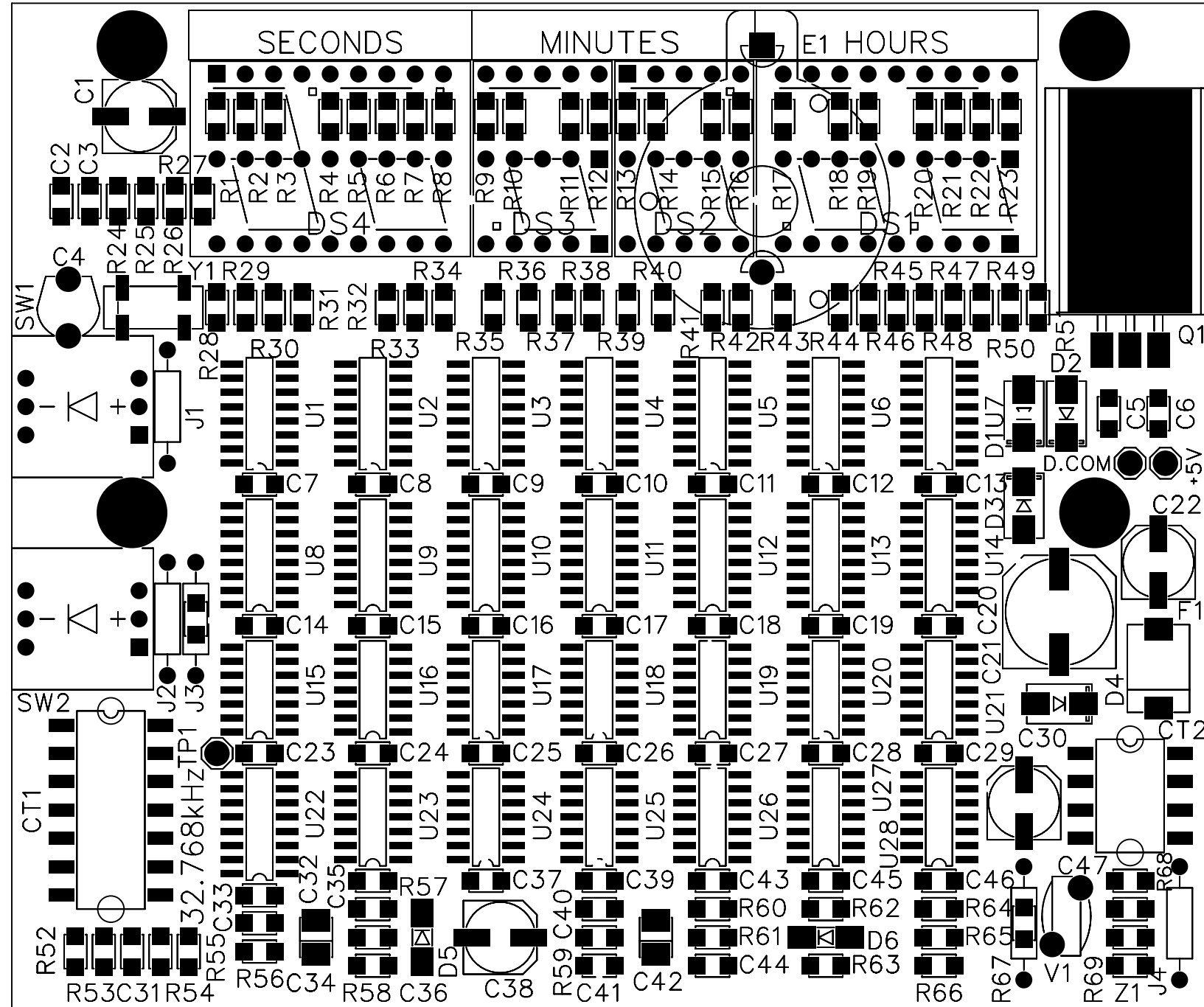

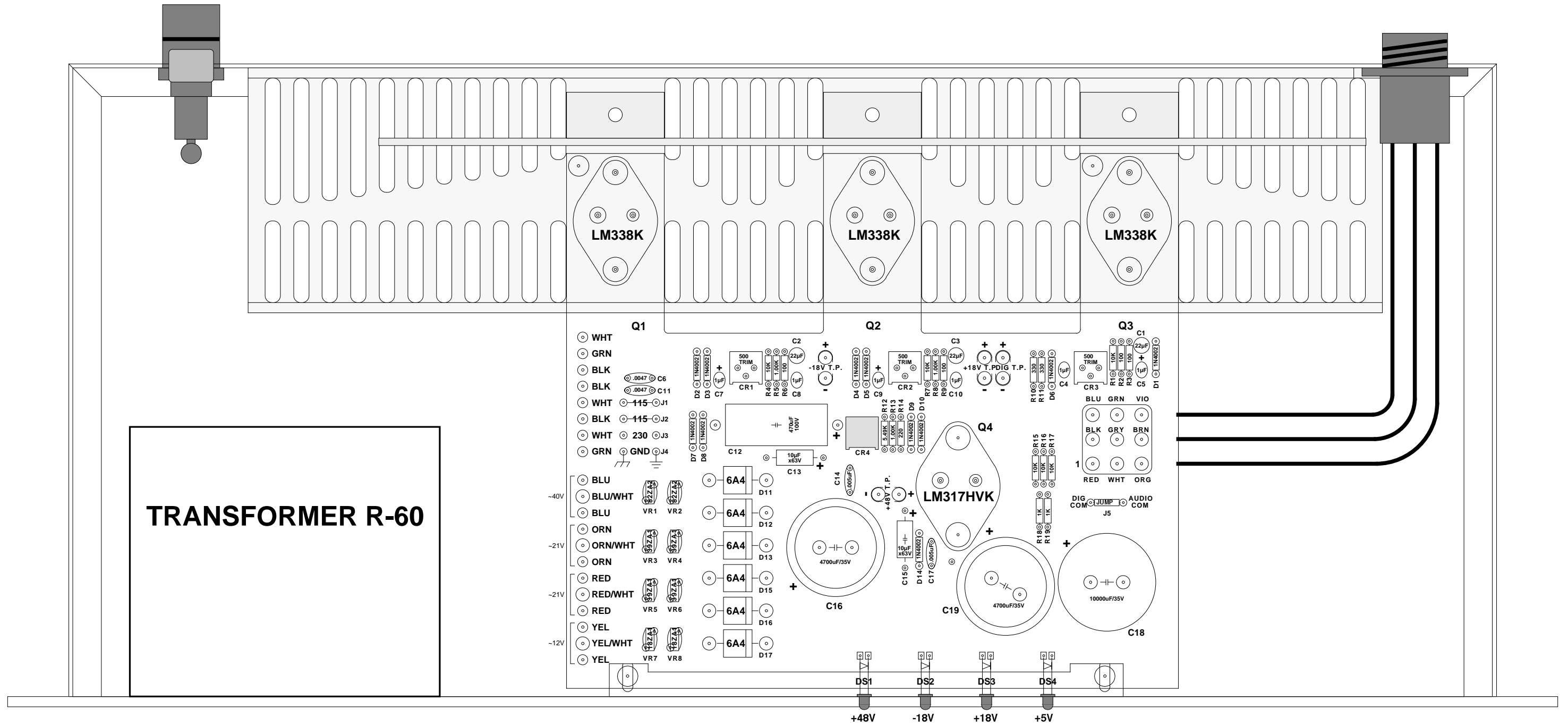

**TRANSFORMER R-60**

100  
220  
1.00K  
5.49K  
10.0K } 1%

WHEATSTONE CORP.  
PS-6040A  
LOAD SHEET  
24L0014A

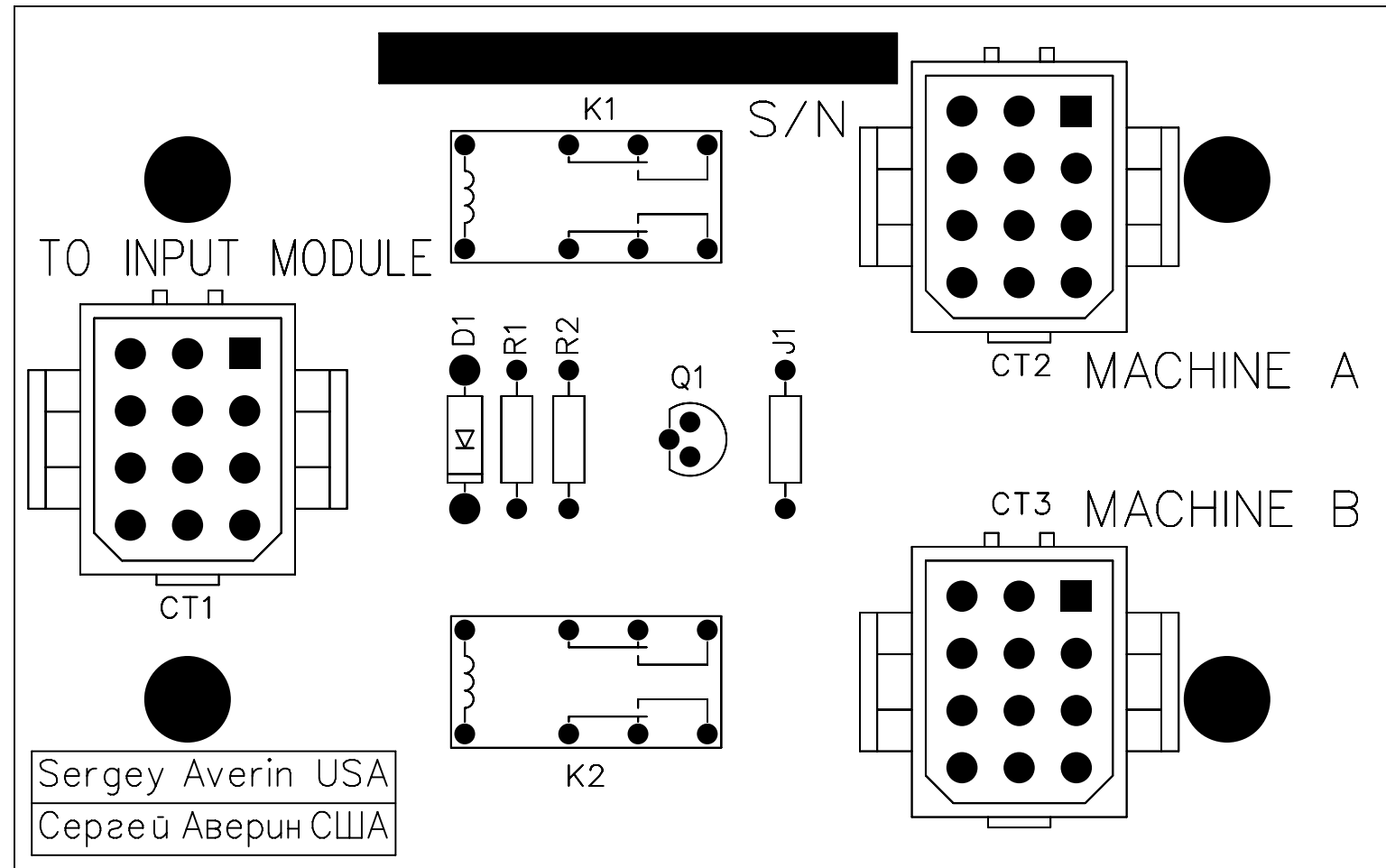



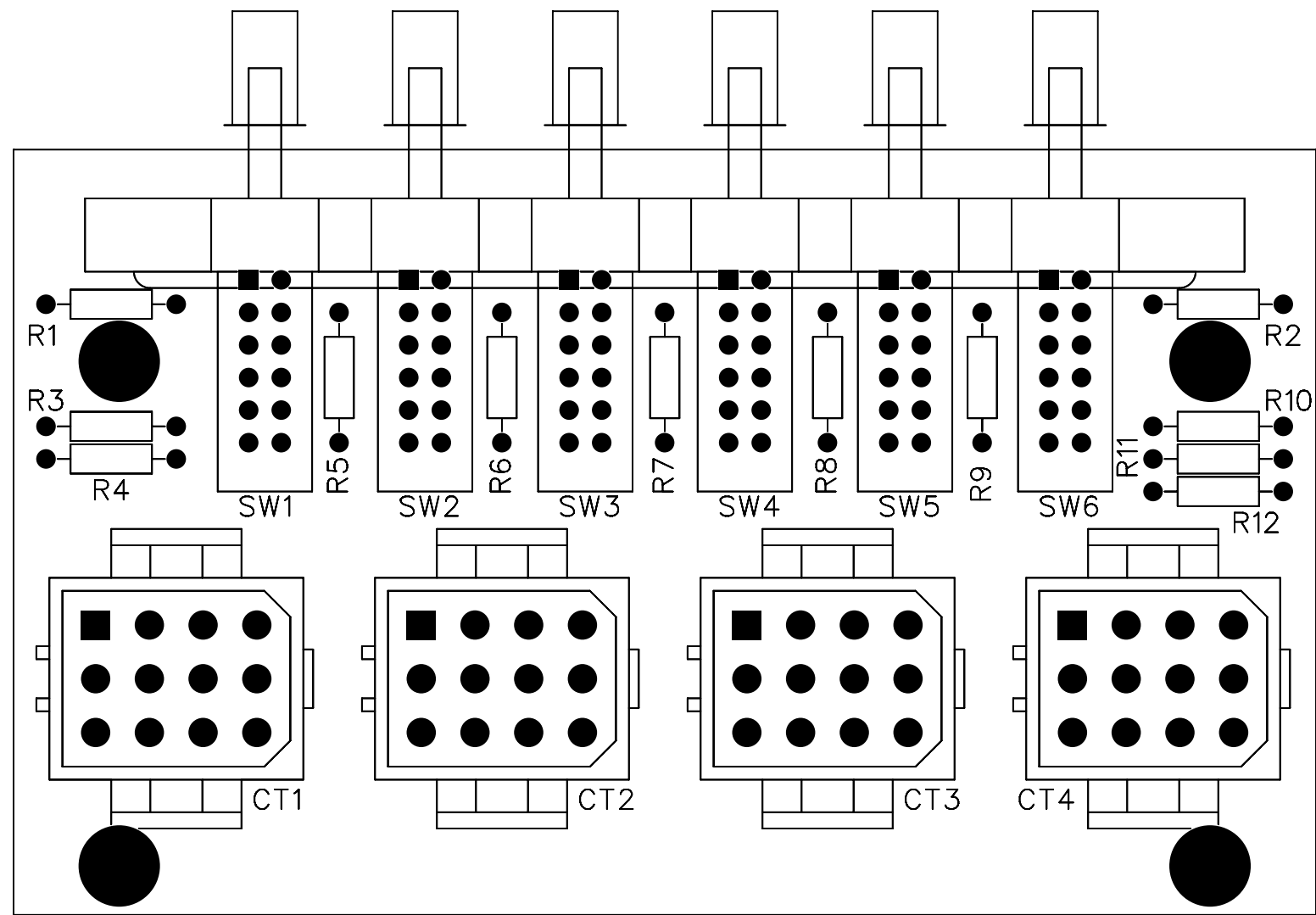

---

# Parts Lists

## Chapter Contents

Completed Modules .....	8-2
IN-60 Input Module .....	8-3
DMP-60 Dual Mic Preamp PCB .....	8-6
SP-60 Simple Phone® Module .....	8-7
TR-60 Tape Remote .....	8-10
OM-60 Output Module .....	8-11
CR-60 Control Room Module .....	8-13
SC-60 Studio Control Module .....	8-16
TM-6 timer .....	8-19
CLK-5 clock .....	8-21
PS-6040 Power Supply .....	8-23
Power Supply Cable .....	8-26
LF-60 Logic Follow PCB .....	8-27
LS-60 Line Selector Panel .....	8-28
Frame-60 - 18 Position Mainframe .....	8-29
EXT-60 Extender Ribbon .....	8-32
Completed sub-assemblies .....	8-33
Spare Parts Kit .....	8-34

<b>PARTS LIST — COMPLETED MODULES</b>		
<b>DESCRIPTION</b>	<b>QTY</b>	<b>WS P/N</b>
IN-60_ INPUT MODULE	1	002400
DMP-60_ DUAL MIC PREAMP MODULE	1	002006
SP-60_ SIMPLE PHONE MODULE	1	002404
TR-60_ TAPE REMOTE MODULE	1	002405
OM-60_ OUTPUT MODULE	1	002401
CR-60_ CONTROL ROOM MODULE	1	002402
SC-60_ STUDIO CONTROL MODULE	1	002403
TM-6_ TIMER UNIT	1	002010
CLK-5_ CLOCK UNIT	1	002011
PS-60_ POWER SUPPLY UNIT	1	007010
LF-60_ LOGIC FOLLOW UNIT	1	002452
LS-60_ LINE SELECTOR UNIT	1	002406
BK-60_ BLANK FACEPLATE	1	002426
SPARE PARTS KIT	1	052475

<b>PARTS LIST — INPUT MODULE</b>			
<b>COMPONENT NO.</b>	<b>DESCRIPTION</b>	<b>QTY</b>	<b>WS P/N</b>
	IN-60 FACEPLATE	1	<i>002420</i>
CT1, CT2	CONN_BOARD-T0-BOARD_8 PIN_R/A	2	<i>220069</i>
CT4, CT5	PLUG_6_PIN_JST	2	<i>230031</i>
CT3	PLUG_9_PIN_JST	1	<i>230032</i>
CT4, CT5	HEADER_6_PIN_JST	2	<i>250065</i>
CT3	HEADER_9_PIN_JST	1	<i>250066</i>
U3	IC, 74ACT00_TTL_SMT	1	<i>305004</i>
U4	IC, 74ACT08_TTL_SMT	1	<i>305006</i>
U2	IC, 74ALS09_TTL_SMT	1	<i>305007</i>
U9-U11	IC, 74LS74_TTL_SMT	3	<i>305029</i>
U5, U12-U14	IC, NE5532_DUAL LINEAR OP-AMP_SMT	4	<i>325001</i>
Q6	TRANSISTOR, MMBTA05 NPN_SMT	1	<i>345001</i>
Q1-Q5	TRANSISTOR, MMBTA55 PNP_SMT	5	<i>345002</i>
D3, D4, D6	DIODE_1N4002W RECTIFYING_1AMP_SMT	3	<i>355001</i>
D1, D2, D5	DIODE_1N4148 FAST SWITCHING_SMT	3	<i>355003</i>
U1, U6-U8	IC_4053_SMT	4	<i>385000</i>

<b>PARTS LIST — INPUT MODULE</b>			
<b>COMPONENT NO.</b>	<b>DESCRIPTION</b>	<b>QTY</b>	<b>WS P/N</b>
C6, C20-C23, C26, C27	CAPACITOR, 22 $\mu$ F 25V ELECTROLYTIC SMT	7	<b>405002</b>
C3, C7, C8, C11, C17, C24, C25, C35, C36	CAPACITOR, 100 $\mu$ F 25V ELECTROLYTIC SMT	9	<b>405003</b>
C1, C2, C5	CAPACITOR, 1 $\mu$ F 35V ELECTROLYTIC SMT TANTALUM	3	<b>405005</b>
C10, C12, C37, C38, C40-C42, C44-C48	CAPACITOR, 10pF 100V CERAMIC SMT	12	<b>415001</b>
C4, C9, C13-C16, C18, C19, C39, C43	CAPACITOR, .1 $\mu$ F 50V CERAMIC SMT	10	<b>415007</b>
C28-C34	CAPACITOR, .22 $\mu$ F 50V CERAMIC SMT	7	<b>415009</b>
R33-R35, R46	RESISTOR_10 _SMT_1206	4	<b>435002</b>
R1, R6, R49, R67, R89, R90	RESISTOR_100 _SMT_1206	6	<b>435007</b>
R8, R9, R12-R16, R57, R59, R61, R64, R65	RESISTOR_220 _SMT_1206	12	<b>435009</b>
R19, R20, R36-R39, R51, R52, R58, R60, R62, R63, R66	RESISTOR_1.00K_SMT_1206	13	<b>435015</b>
R47, R48	RESISTOR_2.43K_SMT_1206	2	<b>435020</b>
R2-R5, R40-R45	RESISTOR_3.32K_SMT_1206	10	<b>435021</b>
R7, R10, R11, R17, R50, R68-R80	RESISTOR_4.99K_SMT_1206	18	<b>435023</b>
R18, R21-R28, R53-R56, R81-R88	RESISTOR_10.0K_SMT_1206	21	<b>435028</b>
R31, R32	RESISTOR_22.1K_SMT_1206	2	<b>435036</b>
R29, R30	RESISTOR_88.7K_SMT_1206	2	<b>435043</b>
CR1, CR2	POT, TRIM, HOR 50K SMT	2	<b>505003</b>

<b>PARTS LIST — INPUT MODULE</b>			
<b>COMPONENT NO.</b>	<b>DESCRIPTION</b>	<b>QTY</b>	<b>WS P/N</b>
<i>(see also sub-assembly #052401, p. 8-33)</i>	SWITCH, PUSHBUTTON, 2 POLE MOMENTARY (LUGS)	2	<b>510080</b>
	HIGH PROFILE SWITCH, GREEN LED / NO CAP	1	<b>510094</b>
	HIGH PROFILE SWITCH, RED LED / NO CAP	2	<b>510095</b>
	HIGH PROFILE SWITCH, YELLOW LED / NO CAP	2	<b>510096</b>
SW1	SWITCH, DIP, 7 POS SMT	1	<b>515002</b>
	KNOB, FDR 8000 WHT	1	<b>520047</b>
	LENS, R60 OFF	1	<b>530048</b>
	LENS, R60 ON	1	<b>530049</b>
	CLEAR BUTTON WITH WHITE FRAME AND YELLOW DIFFUSER	1	<b>530265</b>
	CLEAR BUTTON WITH WHITE FRAME AND RED DIFFUSER	1	<b>530266</b>
	CLEAR BUTTON WITH WHITE FRAME AND WHITE DIFFUSER	3	<b>530267</b>
<i>(see also sub-assembly #052400, p. 8-33)</i>	FADER, P&G STEREO 8122	1	<b>540023</b>
	LED, LAMP REPLACEMENT	1	<b>600025</b>
	LED, LAMP REPLACEMENT, YELLOW	1	<b>600029</b>
	PRINTED CIRCUIT BOARD, SI60	1	<b>700187</b>
	PRINTED CIRCUIT BOARD, INS60	1	<b>700196</b>
	NUT, REM	3	<b>821009</b>
	BRACKET, SWITCH CARD	2	<b>823035</b>
F1-F3	FUSE/POLYSWITCH .3AMP SMT RESETABLE	3	<b>835001</b>

<b>PARTS LIST — DUAL MIC PREAMP</b>			
<b>COMPONENT NO.</b>	<b>DESCRIPTION</b>	<b>QTY</b>	<b>WS P/N</b>
CT1, CT2	CONNECTOR, 12 PIN PC MOUNT	2	220014
CONNECTOR KIT	PLUG, 12 PIN AMP	2	230016
CONNECTOR KIT	PINS, FEMALE SILVER AMP	24	230017
U1-U3, CT3	SOCKET, 8 PIN DIP SMT	4	245001
	CONNECTOR, 8 PIN DIP	2	250010
U1, U3	IC, 2017 MIC PREAMP	2	320003
U2	IC, NE5532 DUAL OP-AMP	1	320008
Z1-Z8	DIODE, C5V1 SMT ZENER	8	355002
C3-C5, C19-C21	CAPACITOR, 10 $\mu$ F 50V ELECTROLYTIC SMT	6	405001
C7, C16	CAPACITOR, 22 $\mu$ F 25V ELECTROLYTIC SMT	2	405002
C8, C11, C12, C22	CAPACITOR, 100 $\mu$ F 25V ELECTROLYTIC SMT	4	405003
L1, L3, L4, L6	FERRITE BEAD SMT 1206 PACKAGE	4	405010
C6, C15	CAPACITOR, 33pF 100V CERAMIC SMT	2	415002
C9, C10	CAPACITOR, 330pF 100V CERAMIC SMT	2	415004
C1, C2, C17, C18	CAPACITOR, .001 $\mu$ F 50V CERAMIC SMT	4	415005
C13, C14	CAPACITOR, .1 $\mu$ F 50V CERAMIC SMT	2	415007
R4, R6, R8, R13, R15, R17	RESISTOR, 10 SMT 1206	6	435002
R3, R20	RESISTOR, 1.30K SMT 1206	2	435016
R1, R2, R18, R19	RESISTOR, 4.99K SMT 1206	4	435023
R5, R9-R12, R14	RESISTOR, 10.0K SMT 1206	6	435028
R7, R16	RESISTOR, 53.6K SMT 1206	2	435041
CR1, CR2	POT, TRIM HOR 1K SMT	2	505001
PCB_DMP60	PRINTED CIRCUIT BOARD, DMP60	1	700201
	NUT, PEM	4	821009
F1, F2	FUSE/ POLYSWITCH .3AMP SMT RESETABLE	2	835001

<b>PARTS LIST — SIMPLEPHONE MODULE</b>			
<b>COMPONENT NO.</b>	<b>DESCRIPTION</b>	<b>QTY</b>	<b>WS P/N</b>
	SP-60_FACEPLATE	1	002424
CT1, CT2	CONN_BOARD-TO-BOARD_8 PIN_R/A	2	220069
CONNECTOR KIT	PLUG_12_PIN_AMP	2	230016
CONNECTOR KIT	PINS_FEMALE_SILVER_AMP	24	230017
CT3	PLUG_5 PIN_JST	1	230030
CT4, CT5	PLUG_6 PIN_JST	2	230031
U3	SOCKET_20 PIN_DIP_SMT	1	245004
CT3	HEADER_5 PIN_JST	1	250064
CT4, CT5	HEADER_6 PIN_JST	2	250065
U1	IC_74ACT32_TTL_SMT_QUAD 2-INPUT OR	1	305010
U2	IC_74AC14_TTL_SMT_TAPE & REEL ONLY	1	305027
U4	IC_74HC30_TTL_SMT_8-INPUT NAND	1	305028
U3	IC_GAL16V8_PAL "SPXA-60"	1	310026
U5, U10-U12	IC_NE5532 DUAL LINEAR OP-AMP_SMT	4	325001
Q2, Q3	TRANSISTOR_MMBTA05_NPN_SMT	2	345001
Q1	TRANSISTOR_MMBTA55_PNP_SMT	1	345002
Z1	DIODE_6.2V 1W_ZENER_SMT	1	350013
D1, D4, D5	DIODE_1N4002W RECTIFYING 1AMP_SMT	3	355001
D2, D3	DIODE_1N4148 FAST SWITCHING_SMT	2	355003
U6-U9	IC_4053_SMT	4	385000



<b>PARTS LIST — SIMPLEPHONE MODULE</b>			
<b>COMPONENT NO.</b>	<b>DESCRIPTION</b>	<b>QTY</b>	<b>WS P/N</b>
C6, C7, C12, C30-C34	CAPACITOR_22 $\mu$ F_25V_ELECTROLYTIC_SMT	8	405002
C4, C5, C8, C13, C14, C19	CAPACITOR_100 $\mu$ F_25V_ELECTROLYTIC_SMT	6	405003
C10	CAPACITOR_1 $\mu$ F_35V_ELECTROLYTIC_SMT	1	405005
C15, C16, C25-C27, C35, C37-C39	CAPACITOR_10pF_100V_CERAMIC_SMT	9	415001
C2, C9, C11, C17, C18, C24, C28, C29, C36	CAPACITOR_1 $\mu$ F_50V_CERAMIC_SMT	9	415007
C1, C2, C20-C23	CAPACITOR_22 $\mu$ F_50V_CERAMIC_SMT	6	415009
R48	RESISTOR_3.3 _SMT_1206	1	435001
R36, R38, R56, R61	RESISTOR_10 _SMT_1206	4	435002
R16, R44-R47, R54, R58, R60	RESISTOR_100 _SMT_1206	8	435007
R3-R6, R19, R27-R29, R31, R33	RESISTOR_220 _SMT_1206	10	435009
R1, R2, R9, R10, R22, R23, R26, R30, R32, R34, R35	RESISTOR_1.00K_SMT_1206	11	435015
R7, R8, R17	RESISTOR_1.30K_SMT_1206	3	435016
R49, R55	RESISTOR_1.69K_SMT_1206	2	435017
R24, R25	RESISTOR_2.43K_SMT_1206	2	435020
R18	RESISTOR_3.32K_SMT_1206	1	435021
R15, R37, R39	RESISTOR_4.99K_SMT_1206	3	435023
R50, R52	RESISTOR_8.45K_SMT_1206	2	435026
R12-R14, R20, R42, R43, R57, R59, R62, R63	RESISTOR_10.0K_SMT_1206	10	435028
R11, R21	RESISTOR_11.0K_SMT_1206	2	435029
R41	RESISTOR_22.1K_SMT_1206	1	435036
R51, R53	RESISTOR_53.6K_SMT_1206	2	435041
R40	RESISTOR_88.7K_SMT_1206	1	435043

<b>PARTS LIST — SIMPLEPHONE MODULE</b>			
<b>COMPONENT NO.</b>	<b>DESCRIPTION</b>	<b>QTY</b>	<b>WS P/N</b>
CR1	POT_TRIM_HOR_10K_SMT	1	505002
<i>(see also sub-assembly #052401, p. 8-33)</i>	SWITCH, PUSHBUTTON, 2 POLE MOMENTARY (LUGS)	2	510080
	HIGH PROFILE SWITCH, GREEN LED / NO CAP	1	510094
	HIGH PROFILE SWITCH, RED LED / NO CAP	1	510095
	HIGH PROFILE SWITCH, YELLOW LED / NO CAP	2	510096
SW1	SWITCH, 4 POSITION SMT DIP , TAPE SEALED	1	515001
	KNOB_FDR_8000_BLUE	1	520042
	LENS_R60_OFF	1	530048
	LENS_R60_ON	1	530049
	CLEAR BUTTON WITH WHITE FRAME AND YELLOW DIFFUSER	1	530265
	CLEAR BUTTON WITH WHITE FRAME AND WHITE DIFFUSER	3	530267
<i>(see also sub-assembly #052404, p. 8-33)</i>	FADER, 10K SINGLE AUDIO TAPER , 8000 SERIES	1	540022
	LED_LAMP_REPLACEMENT	1	600025
	LED_LAMP_REPL_YLW	1	600029
	PRINTED CIRCUIT BOARD, SP60	1	700191
	PRINTED CIRCUIT BOARD, INS60	1	700196
	NUT_PEM	3	821009
	BRACKET_SWITCH_CARD	2	823035
F1-F3	FUSE/ POLYSWITCH .3AMP SMT RESETABLE	3	835001

<b>PARTS LIST — TAPE REMOTE</b>			
<b>COMPONENT NO.</b>	<b>DESCRIPTION</b>	<b>QTY</b>	<b>WS P/N</b>
	TR-60FF FACEPLATE	1	002425
	CONN, BOARD-TO-BOARD, 8 PIN R/A	3	220069
	PLUG, 12 PIN AMP	2	230016
	PINS, FEMALE, SILVER AMP	24	230017
R1-R6	RESISTOR, 1.0K	6	430221
	HIGH PROFILE SWITCH, GREEN LED / NO CAP	2	510094
	HIGH PROFILE SWITCH, RED LED / NO CAP	2	510095
	HIGH PROFILE SWITCH, YELLOW LED / NO CAP	2	510096
	GREEN SWITCH CAP	1	530001
	CLEAR BUTTON WITH WHITE FRAME AND YELLOW DIFFUSER	1	530265
	CLEAR BUTTON WITH WHITE FRAME AND RED DIFFUSER	1	530266
	CLEAR BUTTON WITH WHITE FRAME AND WHITE DIFFUSER	3	530267
	PRINTED CIRCUIT BOARD, TR60	1	700192
	PRINTED CIRCUIT BOARD, TCS60	1	700195
	NUT, PEM	3	821009
	BRACKET, SWITCH CARD	3	823035

<b>PARTS LIST — OUTPUT MODULE</b>			
<b>COMPONENT NO.</b>	<b>DESCRIPTION</b>	<b>QTY</b>	<b>WS P/N</b>
	OM-60_FACEPLATE	1	002421
CT1-CT3	CONN_BOARD-TO-BOARD_8 PIN_R/A	3	220069
U2	IC_74LS74_TTL_D-TYPE_SMT	1	305029
U3	IC_74ACT02_TTL_QUAD 2-INPUT_SMT	1	305040
U1, U4, U9, U10-U12	IC_NE5532 DUAL LINEAR OP-AMP_SMT	6	325001
U5, U6	IC_OP-275 DUAL LINEAR OP-AMP_SMT	2	325002
U7, U8	IC_TL072 DUAL LINEAR OP-AMP_SMT	2	325003
D1	DIODE_1N4002W RECTIFYING 1AMP_SMT	1	355001
D2	DIODE_1N4148 FAST SWITCHING_SMT	1	355003
D3, D4	DIODE_1SS14 SCHOTTKY_SMT	2	355004
C6	CAPACITOR_22µF_25V_ELECTROLYTIC_SMT	1	405002
C5-C8, C15, C31, C32	CAPACITOR_100µF_25V_ELECTROLYTIC_SMT	7	405003
C1, C3, C9, C10, C12, C13, C24, C34, C38, C40, C42, C44	CAPACITOR_10pF_100V_CERAMIC_SMT	12	415001
C16, C17, C19, C20, C27-C30, C33, C35-C37	CAPACITOR_33pF_100V_CERAMIC_SMT	12	415002
C2, C11, C14, C18, C21-C23, C25, C39, C41, C43, C45	CAPACITOR_1µF_50V_CERAMIC_SMT	12	415007
C4	CAPACITOR_22µF_50V_CERAMIC_SMT	1	415009
R14, R19, R20, R24, R25, R27, R60, R62, R64, R66, R71, R73, R75, R85, R88, R91, R94	RESISTOR_10 _SMT_1206	17	435002
R39-R42, R86, R87, R89, R90, R92, R93, R95, R96	RESISTOR_100 _SMT_1206	12	435007
R6-R9	RESISTOR_220 _SMT_1206	4	435009
R11, R12	RESISTOR_475 _SMT_1206	2	435011
R1-R3, R5, R10, R48, R49, R68, R70	RESISTOR_1.00K_SMT_1206	9	435015
R15-R17, R45, R52, R55, R56, R59	RESISTOR_2.43K_SMT_1206	8	435020
R28-R31	RESISTOR_3.32K_SMT_1206	4	435021
R53, R54, R57, R58	RESISTOR_3.92K_SMT_1206	4	435022
R61, R63, R65, R67	RESISTOR_4.99K_SMT_1206	4	435023
R4, R13, R18, R21-R23, R26, R32, R33, R35-R38, R50, R51, R69, R72, R74, R76-R84	RESISTOR_10.0K_SMT_1206	27	435028
R43, R44, R46, R47	RESISTOR_20.0K_SMT_1206	4	435034
R34	RESISTOR_22.1K_SMT_1206	1	435036

<b>PARTS LIST — OUTPUT MODULE</b>			
<b>COMPONENT NO.</b>	<b>DESCRIPTION</b>	<b>QTY</b>	<b>WS P/N</b>
CR1-CR8	POT_TRIM_HOR_10K_SMT	8	505002
	HIGH PROFILE SWITCH, GREEN LED / NO CAP	1	510094
	HIGH PROFILE SWITCH, RED LED / NO CAP	1	510095
	HIGH PROFILE SWITCH, YELLOW LED / NO CAP	2	510096
SW1	SWITCH, 4 POSITION SMT DIP	1	515001
	GREEN SWITCH CAP	1	530001
	CLEAR BUTTON WITH WHITE FRAME AND YELLOW DIFFUSER	1	530265
	CLEAR BUTTON WITH WHITE FRAME AND RED DIFFUSER	1	530266
	CLEAR BUTTON WITH WHITE FRAME AND WHITE DIFFUSER	1	530267
	PRINTED CIRCUIT BOARD, OM60	1	700188
	PRINTED CIRCUIT BOARD, TCS60	1	700195
	SCR_440X3/16_PH_PAN	3	820019
	SCR_440X3/8_PH_FLAT_UNDERCUT	4	820020
	NUT, PEM	4	821009
	SPACER_NYLON_.187	4	823014
	BRACKET_SWITCH_CARD	3	823035
F1-F3	FUSE/ POLYSWITCH .3AMP SMT RESETABLE	3	835001

<b>PARTS LIST — CONTROL ROOM MODULE</b>			
<b>COMPONENT NO.</b>	<b>DESCRIPTION</b>	<b>QTY</b>	<b>WS P/N</b>
	CR-60 FACEPLATE	1	002422
CT1, CT2	CONN_BOARD-TO-BOARD 8 PIN R/A	2	220069
CT3	PLUG_3PIN JST	1	230028
CT4, CT5	PLUG_6PIN JST	2	230031
	RTS JACK	1	260005
U4-U6	IC_74ACT74TTL_SMT_DUAL_D-TYPE	3	305021
U10	IC_74AC14 TTL SMT TAPE & REEL ONLY	1	305027
U11	IC_74HC30 TTL SMT	1	305028
U2, U3	IC_74ACT02 TTL SMT QUAD 2-INPUT NOR	2	305040
U18, U19, U22	LM675_POWER OP AMP	3	320007
U1, U9, U16, U20, U21, U23	IC_NE5532_DUAL LINEAR OP-AMP SMT	6	325001
U17	IC_OP275_DUAL LINEAR OP-AMP SMT	1	325002
Q1	TRANSISTOR_MMBTA05 NPN SMT	1	345001
Z1	DIODE_ZENER_1N4735	1	350013
D1, D2	DIODE_1N4002W RECTIFYING SMT	2	355001
U7, U8, U12-U15	IC_4053 SMT	6	385000

<b>PARTS LIST — CONTROL ROOM MODULE</b>			
<b>COMPONENT NO.</b>	<b>DESCRIPTION</b>	<b>QTY</b>	<b>WS P/N</b>
C5-C8, C19, C56, C57, C66, C67	CAPACITOR_22μF 25V ELECTROLYTIC SMT	9	405002
C1, C4, C20, C21, C23, C24, C38	CAPACITOR_100μF 25V ELECTROLYTIC SMT	7	405003
C22, C42	CAPACITOR_330μF 25V ELECTROLYTIC SMT	2	405004
C14, C34, C43, C46, C49, C50, C59, C61	CAPACITOR_1μF 35V ELECTROLYTIC SMT TANTALUM	8	405005
C2, C36, C37, C63, C65, C68, C69, C71-C74	CAPACITOR_10pF 100V CERAMIC SMT	11	415001
C3, C10, C27, C39, C51, C54, C55, C60, C62	CAPACITOR_33pF 100V CERAMIC SMT	9	415002
C44, C47, C52	CAPACITOR_330pF 100V CERAMIC SMT	3	415004
C35	CAPACITOR_.001μF 50V CERAMIC SMT	1	415005
C9, C12, C13, C15-C18, C25, C26, C28, C29, C40, C41, C58, C64, C70	CAPACITOR_1μF 50V CERAMIC SMT	16	415007
C11, C30-C33, C45, C48, C53	CAPACITOR_.22μF 50V CERAMIC SMT	8	415009
R65, R66, R88, R89, R91, R92	RESISTOR_3.3 _SMT_1206	6	435001
R18, R22, R32, R49, R55, R70, R72	RESISTOR_10 _SMT_1206	7	435002
R16, R17, R67, R68, R74, R76	RESISTOR_100 _SMT_1206	6	435007
R4-R11, R14, R15	RESISTOR_220 _SMT_1206	10	435009
R1-R3, R12, R13, R52, R58, R60-R63	RESISTOR_1.00K_SMT_1206	11	435015
R35, R57, R59	RESISTOR_2.43K_SMT_1206	3	435020
R40-R48	RESISTOR_3.32K_SMT_1206	8	435021
R51, R56, R93-R97, R100, R101, R104	RESISTOR_4.99K_SMT_1206	10	435023
R19, R20, R23-R25, R28, R29, R36-R40, R53, R54, R69, R71, R73, R75, R77-R86, R98, R99, R102, R103, R105-R108	RESISTOR_10.0K_SMT_1206	36	435028
R21, R26, R27, R30, R31, R33, R34, R50, R87, R90	RESISTOR_40.2K_SMT_1206	11	435039
(see also sub-assembly #052402, pg.8-33)	POT_10K BOURNS_DUAL AUDIO	2	500029
(see also sub-assembly #052402, pg.8-33)	POT_10K BOURNS_SINGLE AUDIO	1	500058

<b>PARTS LIST — CONTROL ROOM MODULE</b>			
<b>COMPONENT NO.</b>	<b>DESCRIPTION</b>	<b>QTY</b>	<b>WS P/N</b>
	HIGH PROFILE SWITCH, GREEN LED / NO CAP	1	<b>510094</b>
	HIGH PROFILE SWITCH, RED LED / NO CAP	3	<b>510095</b>
	HIGH PROFILE SWITCH, YELLOW LED / NO CAP	1	<b>510096</b>
SW1	SWITCH_4 POSITION_SMT_DIP_TAPE SEALED	1	<b>515001</b>
	KNOB_SIFAM_GREY COLLET 1/4 G99	2	<b>520038</b>
	KNOB_COLLET 1/8	1	<b>520053</b>
	CAP_SIFAM BLUE NEW	1	<b>530045</b>
	CAP_SIFAM PASTEL GRN	1	<b>530079</b>
	CAP_SIFAM CREAM 15MM	1	<b>530080</b>
	CLEAR BUTTON WITH WHITE FRAME AND RED DIFFUSER	2	<b>530266</b>
	CLEAR BUTTON WITH WHITE FRAME AND WHITE DIFFUSER	3	<b>530267</b>
	RELAY_NEC_DPDT 5V	1	<b>550006</b>
	PRINTED CIRCUIT BOARD_CR60	1	<b>700189</b>
	PRINTED CIRCUIT BOARD_MS60	1	<b>700197</b>
	PRINTED CIRCUIT BOARD_BPSA1000	1	<b>700299</b>
	NUT, REM	3	<b>821009</b>
	WASHER_FLAT 2168	1	<b>822007</b>
	WASHER_SHOULDER	1	<b>822008</b>
	BRACKET, SWITCH CARD	2	<b>823035</b>
	HEATSINK_LM675 W/PIN	3	<b>825010</b>
F4-F6	FUSE_.17 AMP	3	<b>830043</b>
F1	FUSE/POLYSWITCH_.3AMP_SMT_RESETTABLE	1	<b>835001</b>
F2, F3	FUSE/POLYSWITCH_1AMP_SMT_RESETTABLE	2	<b>835002</b>



<b>PARTS LIST — STUDIO MODULE</b>			
<b>COMPONENT NO.</b>	<b>DESCRIPTION</b>	<b>QTY</b>	<b>WS P/N</b>
	SC-60 FACEPLATE	1	002423
CT1, CT2	CONN_BOARD-TO-BOARD 8 PIN R/A	2	220069
CT4	PLUG_6PIN JST	1	230031
CT4	HEADER_6PIN JST	1	250065
U4-U6	IC_74ACT74 TTL SMT DUAL D-TYPE	3	305021
U9	IC_74AC14 TTL SMT TAPE & REEL ONLY	1	305027
U10	IC_74HC30 TTL SMT	1	305028
U2, U3	IC_74ACT02 TTL SMT QUAD 2-INPUT NOR	2	305040
U1, U8, U15, UU17-U19	IC_NE5532 DUAL LINEAR OP-AMP SMT	6	325001
U16	IC_OP-275 DUAL LINEAR OP-AMP SMT	1	325002
Z1	DIODE_ZENER_1N4735	1	350013
D1	DIODE_1N4002W RECTIFYING SMT	1	355001
U7, U11-U14	IC_4053 SMT	5	385000
C1, C5, C6, C17, C37, C45, C46, C52, C53	CAPACITOR_22μF 25V ELECTROLYTIC SMT	9	405002
C2, C18, C19, C21, C33, C38-C40	CAPACITOR_100μF 25V ELECTROLYTIC SMT	8	405003
C12, C29	CAPACITOR_1μF 35V ELECTROLYTIC SMT TANTALUM	2	405005
C3, C31, C32, C41, C42, C49, C51, C54, C55, C57-C60	CAPACITOR_10pF 100V CERAMIC SMT	13	415001
C4, C8, C20, C34, C35, C43	CAPACITOR_33pF 100V CERAMIC SMT	6	415002
C30	CAPACITOR_.001μF 50V CERAMIC SMT	1	415005
C7, C10, C11, C13-C16, C22-C24, C36, C44, C47, C48, C50, C56	CAPACITOR_.1μF 50V CERAMIC SMT	16	415007
C9, C25-C28	CAPACITOR_.22μF 50V CERAMIC SMT	5	415009

<b>PARTS LIST — STUDIO MODULE</b>			
<b>COMPONENT NO.</b>	<b>DESCRIPTION</b>	<b>QTY</b>	<b>WS P/N</b>
R18, R22, R28, R40, R48, R57, R59, R65	RESISTOR_10 _SMT_1206	8	<b>435002</b>
R16, R17, R54, R55, R61, R63	RESISTOR_100 _SMT_1206	6	<b>435007</b>
R4-R11, R14, R15	RESISTOR_220 _SMT_1206	10	<b>435009</b>
R1-R3, R12, R13, R31, R32, R42, R47, R51, R53	RESISTOR_1.00K_SMT_1206	11	<b>435015</b>
R45, R50, R52	RESISTOR_2.43K_SMT_1206	3	<b>435020</b>
R36-R39	RESISTOR_3.32K_SMT_1206	4	<b>435021</b>
R41, R78-R82, R85, R86, R89	RESISTOR_4.99K_SMT_1206	9	<b>435023</b>
R19-R21, R23-R27, R33, R43, R44, R46, R49, R56, R58, R60, R62, R64, R67-R77, R83, R84, R87, R88, R90-R93	RESISTOR_10.0K_SMT_1206	37	<b>435028</b>
R34, R35	RESISTOR_22.1K_SMT_1206	2	<b>435036</b>
R29, R30, R66	RESISTOR_40.2K_SMT_1206	3	<b>435039</b>
	POT_10K BOURNS_DUAL AUDIO	1	<b>500029*</b>
CR1, CR2	POT_10K HOR TRIM SMT	2	<b>505002</b>
SW2	SWITCH_PUSHBUTTON _2 POLE MOMENTARY PCB MOUNTED	1	<b>510080</b>
	HIGH PROFILE SWITCH, GREEN LED / NO CAP	1	<b>510094</b>
	HIGH PROFILE SWITCH, RED LED / NO CAP	3	<b>510095</b>
	HIGH PROFILE SWITCH, YELLOW LED / NO CAP	1	<b>510096</b>
SW1	SWITCH_4 POSITION SMT DIP	1	<b>515001</b>

\* The designated pot has a blue body. On consoles built prior to July 1997, this pot may be WS P/N 500042 (non-blue body; sub-assembly reference #052403, p. 8-33). Double check before ordering.

<b>PARTS LIST — STUDIO MODULE</b>			
<b>COMPONENT NO.</b>	<b>DESCRIPTION</b>	<b>QTY</b>	<b>WS P/N</b>
	KNOB_SIFAM_COLLET_1/4_G99	1	<b>520038</b>
	CAP_SIFAM BLUE_NEW	1	<b>530045</b>
	LENS_R60_OFF	1	<b>530048</b>
	CLEAR BUTTON WITH WHITE FRAME AND RED DIFFUSER	2	<b>530266</b>
	CLEAR BUTTON WITH WHITE FRAME AND WHITE DIFFUSER	3	<b>530267</b>
	LED_LAMP_REPLACEMENT_YLW	1	<b>600029</b>
	PRINTED CIRCUIT BOARD_SC60	1	<b>700190</b>
	PRINTED CIRCUIT BOARD_MS60	1	<b>700197</b>
	NUT_PEM	3	<b>821009</b>
	BRACKET_SWITCH_CARD	2	<b>823035</b>
F1-F3	FUSE_3AMP_SMT_POLYSWITCH	3	<b>835001</b>

<b>PARTS LIST — TIMER</b>			
<b>COMPONENT NO.</b>	<b>DESCRIPTION</b>	<b>QTY</b>	<b>WS P/N</b>
DS1, DS2	SOCKET_R/A_18_PIN	2	240011
CT1, CT2	SOCKET, 8 PIN DIP SMT	2	245001
U13	IC, 74ACT00 TTL SMT	1	305004
U12	IC, 74ACT08 TTL SMT	1	305006
U11	IC, 74AC14 TTL SMT	1	305027
U10	IC, 74LS74 TTL SMT	1	305029
U1	IC, 74HC4060 TTL SMT	1	305041
U2-U5	IC, 74HC4511 TTL SMT	4	305042
U6-U9	IC, 74HC192 TTL SMT	4	305043
D4, D5	DIODE, 1N4002W RECTIFYING 1AMP SMT	2	355001
D1-D3	DIODE, 1N4148 FAST SWITCHING SMT	3	355003
Y1	CRYSTAL, 32.768KHZ SMT	1	375007
C1, C3	CAPACITOR, 100 $\mu$ F 25V ELECTROLYTIC SMT	2	405003
C7	CAPACITOR, 330 $\mu$ F 25V ELECTROLYTIC SMT	1	405004
C14, C15, C22	CAPACITOR, 1 $\mu$ F 35V ELECTROLYTIC SMT TANTALUM	3	405005
C5	CAPACITOR, TRIMMER	1	410001
C4, C6	CAPACITOR, 10pF 100V CERAMIC SMT	2	415001
C24, C26	CAPACITOR, .001 $\mu$ F 50V CERAMIC SMT	2	415005
C2, C8-C13, C16-C21, C23, C25	CAPACITOR, .1 $\mu$ F 50V CERAMIC SMT	15	415007

<b>PARTS LIST — TIMER</b>			
<b>COMPONENT NO.</b>	<b>DESCRIPTION</b>	<b>QTY</b>	<b>WS P/N</b>
J1	RESISTOR, 3.3 , SMT 1206	1	435001
R35, R37, R41, R44, R45	RESISTOR, 100 , SMT 1206	5	435007
R1-R15, R20-R34, R38	RESISTOR_475 _SMT_1206	31	435011
R42, R43	RESISTOR_1.00K_SMT_1206	2	435015
R39	RESISTOR_4.99K_SMT_1206	1	435023
R36, R40	RESISTOR_10.0K_SMT_1206	2	435028
R16	RESISTOR_330K_SMT_1206	1	435047
R17-R19	RESISTOR_10M_SMT_1206	3	435050
DS1, DS2	DISPLAY_DUAL_CLOCK	2	610003
	PRINTED CIRCUIT BOARD, TM6S	1	700248
F1	FUSE/ POLYSWITCH .3AMP SMT RESETABLE	1	835001

<b>PARTS LIST — CLOCK</b>			
<b>COMPONENT NO.</b>	<b>DESCRIPTION</b>	<b>QTY</b>	<b>WS P/N</b>
DS1, DS4	SOCKET_R/A_18_PIN	2	240011
DS3-4	SOCKET_R/A_20_PIN	1	240014
CT2	SOCKET, 8 PIN DIP SMT	1	245001
CT1	SOCKET,14 PIN DIP SMT	1	245002
	CONNECTOR, 8 PIN DIP	2	250010
U19, U23-U26	IC, 74ACT00 TTL SMT	5	305004
U18, U20, U21, U28	IC, 74ACT08 TTL SMT	4	305006
U16, U27	IC, 74ACT74 TTL SMT	2	305021
U15, U17	IC, 74AC14 TTL SMT TAPE & REEL ONLY	2	305027
U22	IC, 74HC4060 TTL SMT	1	305041
U2-U7	IC, 74HC4511 TTL SMT	6	305042
U1, U8-U14	IC, 74HC192 TTL SMT	8	305043
D2, D4	DIODE, 1N4002W RECTIFYING SMT	2	355001
Z1	DIODE, C5V1 SMT ZENER	1	355002
D5, D6	DIODE, 1N4148 FAST SWITCHING SMT	2	355003
D1, D3	DIODE, SS14 SCHOTTKY SMT	2	355004
V1	VARISTOR_33ZA1	1	360001
Y1	CRYSTAL_32.768KHZ_SMT	1	375007
C1, C22, C30, C38	CAPACITOR, 22 $\mu$ F 25V ELECTROLYTIC SMT	4	405002
C21	CAPACITOR, 330 $\mu$ F 25V ELECTROLYTIC SMT	1	405004
C34, C42	CAPACITOR, 1 $\mu$ F 35V ELECTROLYTIC SMT TANTALUM	2	405005
C4	CAPACITOR, TRIMMER	1	410001
C2, C3	CAPACITOR, 10pF 100V CERAMIC SMT	2	415001
C36, C40, C41, C44, C47	CAPACITOR, .001 $\mu$ F 50V CERAMIC SMT	5	415005
C5-C20, C23-C29, C31-C33, C35, C37, C39, C43, C45, C46	CAPACITOR, .1 $\mu$ F 50V CERAMIC SMT	32	415007

<b>PARTS LIST — CLOCK</b>			
<b>COMPONENT NO.</b>	<b>DESCRIPTION</b>	<b>QTY</b>	<b>WS P/N</b>
J3	RESISTOR_3.3 _SMT_1206	1	<b>435001</b>
R53, R58, R60, R61, R63, R67	RESISTOR_100 _SMT_1206	6	<b>435007</b>
R1-R23, R28-R50	RESISTOR_475 _SMT_1206	46	<b>435011</b>
R64, R65, R69	RESISTOR_1.00K_SMT_1206	3	<b>435015</b>
R52, R54, R56, R68	RESISTOR_3.32K_SMT_1206	4	<b>435021</b>
R51, R55, R59, R62, R66	RESISTOR_10.0K_SMT_1206	5	<b>435028</b>
R57	RESISTOR_40.2K_SMT_1206	1	<b>435039</b>
R24	RESISTOR_330K_SMT_1206	1	<b>435047</b>
R25-R27	RESISTOR_10M_SMT_1206	3	<b>435050</b>
SW2	HIGH PROFILE SWITCH, GREEN LED/ NO CAP	1	<b>510094</b>
SW1	HIGH PROFILE SWITCH, RED LED/ NO CAP	1	<b>510095</b>
	GREEN SWITCH CAP	1	<b>530001</b>
	CLEAR BUTTON WITH WHITE FRAME AND RED DIFFUSER	1	<b>530266</b>
DS1, DS4	DISPLAY, DUAL DIGIT LED	2	<b>610003</b>
DS2, DS3	DISPAYSINGLE DIGIT LED	2	<b>610004</b>
	PRINTED CIRCUIT BOARD, CLK-5S	1	<b>700258</b>
	BATTERY, 3V LITHIUM	1	<b>830000</b>
	BATTERY HOLDER	1	<b>830003</b>
F1	FUSE/ POLYSWITCH .3AMP SMT RESETABLE	1	<b>835001</b>

<b>PARTS LIST — POWER SUPPLY</b>			
<b>COMPONENT NO.</b>	<b>DESCRIPTION</b>	<b>QTY</b>	<b>WS P/N</b>
	PS-60 FACEPLATE	1	007074
	PS-60 CHASSIS	1	007075
	PS-60 COVER	2	007076
	PS-60 HEATSINK, SLOTTED	1	007077
	PS-60 CARD BRACKET	1	007078
	PS-60 HEATSINK FIN	1	007084
	CORD, GRAY POWER	1	150016
	CABLE, PS BLACK, 14/22 AWG	16	150085
	GROUND LUG	1	230003
	CONNECTOR, CABLE MOUNT MULTI-PIN	2	230010
	CONNECTOR, CHASSIS MOUNT MULTI-PIN	1	230011
	STRAIN RELIEF, MULTI-PIN CONNECTOR	2	230012
	PINS, MIL CABLE, FEMALE	18	230014
	PINS, MIL CABLE, MALE	9	230015
	PATCH CLIPS	1	280000
Q4	REG, LM317HVK, POSITIVE ADJUSTABLE	1	330012
Q1-Q3	REG, LM338, POSITIVE ADJUSTABLE	3	330014
D1-D10, D14	DIODE, 1N4002	11	350003
D11-D13, D15-D17	DIODE, POWER , CR6A4	6	350009
VR7, VR8	VARISTOR, 18ZA1	2	360000
VR3-VR6	VARISTOR, 39ZA1	4	360002
VR1, VR2	VARISTOR, 82ZA2	2	360005



<b>PARTS LIST — POWER SUPPLY</b>			
<b>COMPONENT NO.</b>	<b>DESCRIPTION</b>	<b>QTY</b>	<b>WS P/N</b>
C18	CAPACITOR, 10000 $\mu$ F 35V ELECTROLYTIC	1	400006
C13, C15	CAPACITOR, 10 $\mu$ F 63V ELECTROLYTIC	2	400012
C4, C5, C7-C10	CAPACITOR, 1 $\mu$ F 35V TANTALUM ORANGE	6	400014
C1-C3	CAPACITOR, 22 $\mu$ F 25V ELECTROLYTIC	3	400017
C16, C19	CAPACITOR, 4700 $\mu$ F 35V ELECTROLYTIC	2	400019
C12	CAPACITOR, 470UF 100V AXIAL LEAD UL APPROVED ELECTROLYTIC	1	400031
C6, C11, C14, C17	CAPACITOR, .0047 $\mu$ UF 1KV CERAMIC, UL RATED	4	410015
R5, R8 ,R13, R18, R19	RESISTOR, 1.0K, PRECISION	5	430107
R12	RESISTOR, 5.49K, PRECISION	1	430140
R1, R4, R7, R15-R17	RESISTOR, 10.0K, PRECISION	6	430153
R2, R3, R6, R9	RESISTOR, 100 , CARBON	4	430212
R14	RESISTOR, 220 , CARBON	1	430214
R10, R11	RESISTOR, 330 , CARBON	2	430215
CR1-CR3	POT, TRIM HOR 500	3	500019
DS1-DS4	LED, ROUND, RL209	4	600017
	PRINTED CIRCUIT BOARD, PS6040	1	700205
	TRANSFORMER, POWER	1	800005

<b>PARTS LIST — POWER SUPPLY</b>			
<b>COMPONENT NO.</b>	<b>DESCRIPTION</b>	<b>QTY</b>	<b>WS P/N</b>
	SCR, 1032X3/4, HEX SHCS	4	<b>820007</b>
	SCR, 440X1/4, PH PAN	2	<b>820016</b>
	SCR, 440X3/8, PH PAN	18	<b>820021</b>
	SCR, 632X3/8, HEX SOCKET	6	<b>820034</b>
	SCR, 632X3/8, PH PAN S/S	7	<b>820035</b>
	NUT, KEP #4	18	<b>821005</b>
	NUT, KEP #6, SMALL PATTERN	10	<b>821006</b>
	NUT, KEP, ZINC 10	4	<b>821008</b>
	NUT, PEM	2	<b>821009</b>
	STUD, PEM, PS60 LUG	1	<b>821013</b>
	GROMMET, RUBBER 742	4	<b>824005</b>
	STRAIN RELIEF	1	<b>824009</b>
	INSULATOR, MICA	3	<b>825008</b>
	FUSE_1.25_AMP	1	<b>830053</b>
	FUSE_HOLDER	1	<b>830010</b>

<b>PARTS LIST — POWER SUPPLY CABLE</b>		
<b>PART NAME</b>	<b>QTY</b>	<b>WS P/N</b>
CONN, MIL CABLES	2	230010
CABLE, POWER SUPPLY	16	150014
PINS, MIL CABLE, FEMALE	18	230014
STRAIN RELIEF, MIL	2	230012

<b>PARTS LIST — LOGIC FOLLOW</b>			
<b>COMPONENT NO.</b>	<b>DESCRIPTION</b>	<b>QTY</b>	<b>WS P/N</b>
CT1-CT3	CONN_PC_MT_12_PIN	3	220014
	PLUG_12_PIN_AMP	3	230016
	PINS_FEMALE_SILVER_AMP	38	230017
Q1	TRANSISTOR, 2N3906 PNP	1	340006
D1	DIODE, 1N4002	1	350003
J1	RESISTOR, 0	1	430100
R1	RESISTOR, 1.0K	1	430221
R2	RESISTOR, 10K	1	430239
K1, K2	RELAY, DPDT,5V	2	550006
	PRINTED CIRCUIT BOARD, LF60	1	700198
	SCR_440X3/8_PH_PAN	4	820021
	NUT_PEM	4	821009
	SPACER_NYLON_187	2	823014

<b>PARTS LIST — LINE SELECT MODULE</b>			
<b>COMPONENT NO.</b>	<b>DESCRIPTION</b>	<b>QTY</b>	<b>WS P/N</b>
	BRACKET_LS50	1	002082
CT1-CT4	CONN_PC_MT_12_PIN	4	220014
	PLUG_12_PIN_AMP	4	230016
	PINS_FEMALE_SILVER_AMP	48	230017
R1-R12	RESISTOR_10K	12	430239
SW1-SW6	SWITCH_ASSEM_6_BANK	1	510040
	PRINTED CIRCUIT BOARD_LS60	1	700053
	STANDOFF_6-32 X 1.250 HEX ALUM. M/F	4	823018

<b>PARTS LIST — FRAME</b>		
<b>PART NAME</b>	<b>QTY</b>	<b>WS P/N</b>
DMP-60 ASSEMBLY	1	002006
R60 TIMER ASSEMBLY	1	002010
R60 CLOCK ASSEMBLY	1	002011
CLOCK CONTROL ASSEMBLY	1	002012
LS-60 MODULE	1	002406
R-60 EXTENDER RIBBON	1	002418
R60 CLOCK PLEXI	2	002463
R60-18 PAN	1	002473
R60-18 MB REAR	1	002474
R60-18 MB FACE	1	002475
R-60 PWR CONNECTOR BKT *	1	002481
LS-60 BLOCK-OUT	1	002483
R60-18 TIMER / CLOCK BRACKET	1	002485
R60 MANUAL	1	002496
ARMREST_OAK_A50-12	1	100002
SIDEPLATE_R60_RIGHT	1	100034
SIDEPLATE_R60_LEFT	1	100059
HINGE_CONT_CUSTOM	.5	110024
CABLE_26 COND	6	150083

\* (see also sub-assembly  
#052481, p. 8-33)

### FRAME-60 – 18 Position Mainframe Parts List (page 1 of 3)

<b>PARTS LIST — FRAME</b>		
<b>PART NAME</b>	<b>QTY</b>	<b>WS P/N</b>
CONN_CARDEDGE_36_PIN	2	220007
CONN_PC_MT_12_PIN	47	220014
CONN_CARDEDGE_62_PIN	22	220027
GROUND_KIT	1	230001
CONN_MIL_CHASSIS- AMP	1	230011
PINS_MIL_CABLE_MALE	9	230015
PLUG_12_PIN_AMP	53	230016
PINS_FEMALE_SILVER_AMP	636	230017
PLUG_RIBBON_10_PIN	1	230020
PLUG_3_PIN_JST	1	230028
SOCKET_J8_PIN	3	240009
CONN_DIP_8_PIN	1	250010
HEADER_3M_16_PIN_ST	1	250038
PLUG_RIBBON_16_PIN	1	250039
CONN_40_PIN_PLUG (see also sub-assembly #052454 p. 8-33)	2	250053
HEADER_40_PIN_ST (see also sub-assembly #052454 p. 8-33)	2	250056
HEADER_3_PIN_JST	1	250062
HEADER_10_PIN_ST	1	250077
HEADER_MOLEX_9_PIN	1	270023
PINS_MOLEX_SILVER	9	270026
CONN_9 PIN_ FEMALE _4200	1	270027

**FRAME-60 – 18 Position Mainframe Parts List (page 2 of 3)**

<b>PARTS LIST — FRAME</b>		
<b>PART NAME</b>	<b>QTY</b>	<b>WS P/N</b>
PATCH_CLIP_R60_SPACER	10	280004
PATCH_CLIP	1	280005
PATCH_CLIP_R60	11	280007
METER LAMP_6V	1	620006
METER_SP6_AL29WF	4	630004
LIGHT_BOX_AL29_6V	4	630007
PCB_MB60 (see also sub-assembly #002451 p. 8-33)	1	700185
PCB_MB66 (see also sub-assembly #002454 p. 8-33)	1	700186
SCR_MODULE_XTRACTOR_8	0	820046
SCR_#6-18X5/8"PHILLIPS FLAT_S/Z	8	820062
SPACER_NYLON_1/4RD_440	8	823013
STANDOFF_A50	20	823020
TOOL_CRIMP_A50	1	850030
TOOL_EXTRACTOR_A50	1	850032
CUE_SPEAKERS	1	960000

**FRAME-60 – 18 Position Mainframe Parts List (page 3 of 3)**



<b>PARTS LIST — RIBBON EXTENDER</b>		
<b>DESCRIPTION</b>	<b>QTY</b>	<b>WS P/N</b>
CABLE_50 COND	3	150007
CABLE_26 COND	3	150083
CONN_PC_MT_CRIMP_36	2	220019
CONN_S/R_36_PIN	2	220020
CONN_PC_MT_26_PIN	2	220021
CONN_S/R_26_PIN	2	220022
CONN_CARDEDGE_62_PIN	1	220027
PRINTED CIRCUIT BOARD, EXT/2-62	1	700203
PRINTED CIRCUIT BOARD, EXTR62	1	700263

<b>PARTS LIST — SUB ASSEMBLY</b>		
<b>WS P/N</b>	<b>DESCRIPTION</b>	<b>QTY</b>
002451	PRINTED CIRCUIT BOARD, MB60, LOADED	1
002454	PRINTED CIRCUIT BOARD, MB66, LOADED	1
052006	RIBBON CABLE ASSEMBLY, DMP60	1
052400	FADER, WIRED STEREO, IN60	1
052401	SWITCH, WIRED ON/OFF, IN60/SP60 (NO LENS CAP INCLUDED)	1
052402	POT, WIRED CR or HDPN, CR60	1
052405	POT, WIRED CUE, CR60	1
052404	FADER, WIRED MONO, SP60	1
052454	RIBBON CABLE ASSEMBLY, 40 PIN, MB66	1
052481	CONNECTOR, WIRED POWER INTERFACE W/BRKT	1

<b>PARTS LIST — SPARE PARTS KIT</b>		
<b>DESCRIPTION</b>	<b>QTY</b>	<b>WS P/N</b>
SPARE PARTS KIT	1	052475
PLUG_12 PIN_AMP	4	230016
PINS_FEMALE	50	230017
IC_Q4066	1	300005
IC_Q74LS00	1	300041
IC_Q74LS74	1	300046
IC_QGAL16V8	2 - CRX-60 1 - SPXA-60	310026
IC_Q2017	2	320003
IC_QTL072	2	320006
IC_QLM675	1	320007
IC_QNE5532	4	320008
REG_LM338K	1	330014
IC_Q4053	1	380003
POT_10K BOURNS_DUAL AUDIO	1	500029
SWITCH_PUSHBUTTON_2 POLE MOMENTARY	2	510080
FADER_STEREO 8122	1	540023
LED_LAMP REPLACEMENT_A600	1	600025
LED_LAMP REPLACEMENT_YLW	1	600029
METER LAMP_6V	4	620006
SCR_#4/40X3/16 PHILLIPS PANHEAD	10	820019
FUSE_2AMP SLO BLO	2	830007

## Spare Parts Kit Parts List (page 1 of 1)

---

# Troubleshooting

## Chapter Contents

Basic Procedures .....	9-1
Ribbon Extender Cable .....	9-2
Integrated Circuits .....	9-2

## BASIC PROCEDURES

If you have encountered difficulty in testing your installation, check the items listed below before opening the console. Note that some items may seem very obvious; it is often the most obvious things that we overlook.

1. Check that the AC power source for the console is live, and that the power supply is connected to the AC source and to the console.
2. Make sure that the sources you are using to test the console installation are producing normal, line level signals. For example, if a cart machine is the source, is the cart playing? Is the output of it connected to the console?
3. When checking for sound from control room and studio speakers, are the amplifiers on? Are the amplifier volumes turned up to a normal level? Are the speakers connected to the amplifier outputs? Is CUE activated (and interrupting regular source program)? Is an announcer mic input channel ON (and automatically muting control room or studio output)?
4. If you have checked external devices and connections, and feel that the problem is within the console, double check all wiring before attempting to troubleshoot the console itself.

### **NOTE: THE FOLLOWING PRECAUTIONS SHOULD BE TAKEN WHILE TROUBLESHOOTING OR TESTING A "LIVE" (I.E., POWERED-UP) CONSOLE.**

(1) Use extreme care when removing or replacing module faceplates, to prevent shorting switchboard traces against an exposed metal surface. If a module faceplate must be removed, but remain connected while troubleshooting, place a piece of cardboard or other non-conducting material across the console where the faceplate will be placed. This will prevent shorting, and also avoid scratching or marring the faceplates.

(2) Use extreme care when using meter or oscilloscope test probes to avoid shorting a test point to an adjacent connection. This is especially important when probing a pin 7 op-amp output, since the adjacent pin 8 is at 18 volts.

**(3) NEVER remove or insert a logic IC (GAL or CMOS analog switch) while the console is powered. The same applies to the audio op-amps.**

(4) The R-60 console contains static-sensitive devices. Normal precautions against static discharge should be observed when handling individual modules.

## EXT-60 RIBBON EXTENDER CABLE

Every R-60 console comes supplied with a ribbon extender cable, which is designed to be used for servicing, troubleshooting, calibration procedures, etc.—any situation where it is desirable to work on an individual module while it is powered up and fully connected to the console mainframe. The EXT-60 assembly is pretty straightforward: it consists of a short printed circuit board that plugs directly into the module's motherboard connector slot; this board is connector (via dual 36" long ribbon cables) to a second 62-pin connector that accepts the module's edgecard connector fingers. The connection is pin-for-pin and virtually foolproof—AS LONG AS THE FOLLOWING PRECAUTIONS ARE ADHERED TO:

1) when plugging the extender card into the console's motherboard, *note the red edge of the 36 conductor ribbon cable—this should be up, pointing towards the console meterbridge*. This orients the component side of the card correctly in the motherboard slot.

2) likewise the module itself, when being plugged into the connector at the other end of the ribbon cable, **MUST** have its component side facing the cables, so the red edge of the ribbon cable points towards the top of the module.

3) when you plan to use the extender ribbon to work on a powered-up module, be sure to lay the module on a non-conductive surface, so its solder side pads and component leads don't accidentally short out against each other. A piece of cardboard works best; this will also protect your working surface from getting scratched.

If the above precautions are followed you should have no problems. If they are NOT followed and you accidentally plug a module in backwards, serious damage could result.

## INTEGRATED CIRCUITS

The audio circuits of the console consist almost entirely of plug-in IC op-amps. The types called out in the schematic drawings and parts lists are chosen for optimum performance; in an emergency situation other types of known matching pin-out and capability can be temporarily substituted. Some useful troubleshooting hints for these circuits follow.

(1) Due to the large open-loop gain of the typical op-amp, the inverting input of an amplifier, configured as an inverter with its non-inverting input grounded, acts as a “virtual ground,” and signal levels at this point can be expected to be extremely low. However, a circuit fault could result in a large signal level at the inverting input, so it may be worth checking.

(2) When one of these ICs fail, it commonly swings its output to one of the power supply rails. This should be a first check when a bad IC is suspected. Measure the output pin of the IC directly (as opposed to measuring after a coupling capacitor) under a no-signal condition and look for a large DC offset at the output. Note individual R-60 modules are power protected by electronic fuses (“polyswitches”) that automatically isolate the module from the rest of the console in the event of a voltage failure. These will reset once the fault is corrected and they have cooled off.

A polyswitch is a device that switches to a very high impedance state when its current threshold is reached. The device resets to a very low impedance state when the fault condition is cleared.

(3) The capacitive loading effect of a test probe may occasionally cause oscillations in a high gain amplifier circuit. For this reason it is advisable, when using meter probes to measure DC voltage in an amplifier circuit, to isolate the “hot” lead from the circuit under test with a 10K resistor. This introduces a slight measurement error, depending on the meter input impedance, but this error is slight compared to the error that occurs if the amplifier is oscillating. If signal tracing with an oscilloscope, use a low capacity probe.

(4) Because of the feedback loop in the op-amp circuit, sometimes a signal can be measured or heard even when the IC is defective or even removed. Generally this signal will become more and more distorted as the level increases; also the gain of the affected path will be incorrect. Don't assume that because you can observe an output signal the IC must be working properly.

(5) This console has electronically balanced output circuits on its main output channels. Care should be taken when installing or testing these circuits to avoid connecting the “low” side of these outputs to ground or to an input circuit that has a low impedance to ground. While such a connection will not cause immediate damage to the console, levels will be incorrect and distortion figures will rise. If an unbalanced connection must be made to these outputs, let the “low” side float unconnected, or else build it out with a 620 ohm or higher resistor.

(6) The +5 volt logic power available at the individual channel logic ports is connected to the console logic supply through a polyswitch. These devices are provided to limit the current drawn by the user-provided external circuitry. If this voltage appears to be missing at the logic port, but is available elsewhere in the console, the polyswitch for that port has probably become open. Do not defeat the protection offered by these resistors by replacing them with jumper wires. In a pinch any low value 1/4 watt resistor can be used.

(7) In addition to the +/- 18 volts for the op-amps, and the +5 volts for the GAL ICs, the CMOS analog ICs require a +/- 5 volt supply, derived from +/- 18 volts. If this supply is not functional, the GAL outputs experience abnormal loading, which causes some rather weird logic problems. If there appears to be a logic malfunction in one or more channels, check these voltages.

Technical information for the console is contained on the schematic drawings. Installation and hook up information are also summarized in the text of this manual. In general, the R-60 console is rugged and user friendly. Rotary potentiometers are connectorized for easy replacement, as are faders and channel ON/OFF switches. (Note fader knobs should be removed or installed only when the fader is at the end of its travel to avoid “bowing” the internal fader structure.) Modules can be unplugged or plugged in while the console is powered up with no damage, provided the precautions described above concerning removal and replacement of module faceplates are carefully followed. Occasionally, this will cause a transient in the logic system that may be sufficient to affect a channel's ON/OFF or CUE status, but this is rare. If the power cable is being unplugged from the mainframe or the power supply, be sure to first turn the power off to avoid arcing the connector pins.

**AUDIOARTS ENGINEERING maintains an active program of user support and technical assistance. You are encouraged to call the factory with any questions, problems, ideas, or suggestions regarding your R-60 console.**